

**HAAKON INDUSTRIES  
PENTPAK AND AIRPAK  
CUSTOM AIR-HANDLING UNITS**

**INSTALLATION, OPERATION, AND MAINTENANCE MANUAL**



## **Table of Contents**

SECTION 1: INTRODUCTION .....	1	
INTRODUCTION		1
SAFETY		1
SECTION 2: RECEIVING .....	1	
RECEIVING AND INSPECTION		1
TOOL LOCK HANDLES		1
STORAGE		2
CLEARANCES		2
LIFTING AND HANDLING		2
SECTION 3: ASSEMBLY AND INSTALLATION .....	3	
ASSEMBLY AND INSTALLATION OF HAAKON ROOF CURB		3
LIFTING		4
MOUNTING SURFACE		4
ASSEMBLY OF SPLIT UNIT		5
UNIT INSTALLATION ON A ROOF CURB		10
ROOF CURB RESTRAINTS		11
UNIT INSTALLATION ON HOUSEKEEPING PAD		11
INSTALLATION OF HOODS		13
SETTING EARTHQUAKE RESTRAINTS		14
SECTION 4: DAMPERS AND DUCTING .....	16	
DUCT CONNECTIONS		16
DAMPER ACTUATORS		17
DAMPER TORQUE REQUIREMENTS		17
SECTION 5: COILS, DRAINS AND PIPING .....	19	
TRAPPING DRAINS		19
COIL PIPING CONNECTIONS		21
FACTORY SUPPLIED PIPING		21
WATER COIL PIPING		21
STEAM COIL PIPING		21
REFRIGERANT PIPING		22
EVAPORATIVE HUMIDIFIER		23
SECTION 6: ELECTRICAL CONNECTIONS .....	26	
SECTION 7: FILTERS .....	28	
FILTER INSTALLATION		28
SECTION 8: START-UP AND MAINTENANCE .....	41	
START-UP		41
UNIT MAINTENANCE		42
FAN MAINTENANCE		43
MOTOR MAINTENANCE		45
SECTION 9: AIRFLOW DISPLAY AND TROUBLESHOOTING .....	46	
HAAKON CAREL AIRFLOW DISPLAY GUIDE		46
AHU TROUBLESHOOTING:		48
APPENDIX A: DAMPER ACTUATOR MOUNTING .....	50	
APPENDIX B: TABLE OF FIGURES .....	53	

## **SECTION 1: INTRODUCTION**

### **INTRODUCTION**

This manual is intended as a guide for the customer, the installer and the end user of Haakon custom air-handling units. The manual covers standard features and some optional features. Due to the custom nature of the equipment however, not all possibilities are addressed. In cases where a special application is not covered, the customer can obtain information from the Haakon sales representative or the Haakon factory.

### **SAFETY**

The customer must provide qualified personnel and use safe practices when installing and operating the equipment. Consult all local building, occupational safety, electrical, gas, and other codes applicable to the installation.

A variety of optional safety features are available from the manufacturer; it is the responsibility of the customer to determine if the unit is equipped with all of the safety devices required for the particular application. Safety considerations include the accessibility of the equipment to non-service personnel, the provision of electrical lock-out switches, maintenance procedures, and automatic control sequences.

Contact with moving parts can cause personal injury or property damage. Automatic control devices may start the unit without warning. To prevent accidental start-up, the maintenance personnel should always lock-out all power supplies before working on the air-handling unit. Often a unit will have more than one power connection point; disconnect all sources of power before servicing. Even when locked out electrically, fans located in a parallel or series fan system may be subject to wind milling. As an added precaution, the impeller should be secured to restrict rotation (but always ensure that any restrictive device is removed before putting the fan back into service).

Always replace any guarding which has been removed for servicing.

There are a number of safety related issues addressed throughout the manual; read the complete manual before installing or operating the equipment.

## **SECTION 2: RECEIVING**

### **RECEIVING AND INSPECTION**

Haakon HVAC units are inspected and tested prior to shipment to ensure a high standard of quality. Upon receipt of an air-handling unit, conduct a thorough inspection of the casing and internal components. If there is any damage that might have occurred during shipping, immediately file a claim with the carrier.

Compare the items on the packing list with the items in the shipment to verify that all parts have been received. Pay particular attention to any separate components that have shipped along with or inside the unit.

Should repairs or alterations be required, the local representative must be fully informed before any work begins. Unauthorized back charges will not be accepted.

Care must be exercised when working on the roof of an AHU, as damage to the casing integrity may result due to overloading.

### **TOOL LOCK HANDLES**

Some access doors may be equipped with tool lock handles for additional safety.

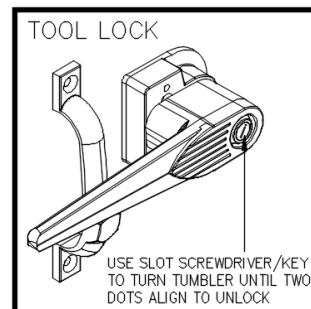

## STORAGE

Failure to follow the procedures outlined below may cause damage to the unit and void the warranty.

1) Unit must be adequately protected from the weather until final installation is complete, and heated when stored outdoors.

**NOTE:** The factory installed poly-wrap is not considered adequate protection against the weather where a unit is stored in an area exposed to the elements! The contractor must fully tarp the unit to protect it from weather and construction damage.

2) Where an indoor unit has been fully installed, but is exposed to the elements due to incomplete building construction, tarping must remain in place to protect the unit until such time the building structure will protect the unit against the elements.

3) Do not remove any factory provided temporary covers or temporary internal support structural until the unit is installed in its design position. **NOTE:** All temporary structural, if any, will be clearly marked as such inside the unit.

4) Units should be stored in a location such that it is protected from excessive vibration and accidental impact.

5) Do not store other equipment on top of, or inside the unit.

6) During extended storage periods, manually rotate the fan wheels and grease the fan bearings a minimum of once a month to prevent bearing damage. **NOTE:** Do not over-grease the bearings as this may rupture the seals and lead to premature bearing failure during operation.

7) To ensure the unit stays in factory condition, and to avoid corrosion, inspect the unit twice weekly during storage. Upon discovery of any moisture on interior

surfaces, immediately heat and ventilate the unit to prevent corrosion.

8) Upon final installation and removal of tarps, remove all temporary opening covers, and temporary internal support structural, and fully dry out the unit before attaching any duct-work.

Failure to adequately protect the unit from the weather during storage may result in surface corrosion of the unit interior, and damage to internal components.

## CLEARANCES

When locating the air-handling unit, pay particular attention to the clearances between the unit and adjacent objects.

The relevant electrical code (NEC or CEC) requires a minimum of 42 inches (1.07 meters) of service space between the face of any electrical enclosure and any wall or obstruction.

Provide sufficient clearance to ensure full access door swings, panel removal and room for piping and wiring ducting. There must be no obstructions to prevent airflow through hoods or louvers. Allow a distance equivalent to the horizontal width of the louver between the louver and any wall facing the louver.

## LIFTING AND HANDLING

Use the factory lifting lugs to raise the unit. Spreader bars are required to prevent damage to the casing and protruding components during a lift. Use all of the lifting lugs on the base channels. Adjust the tension in each line for proper load distribution.

## SECTION 3: ASSEMBLY AND INSTALLATION

### ASSEMBLY AND INSTALLATION OF HAAKON ROOF CURB

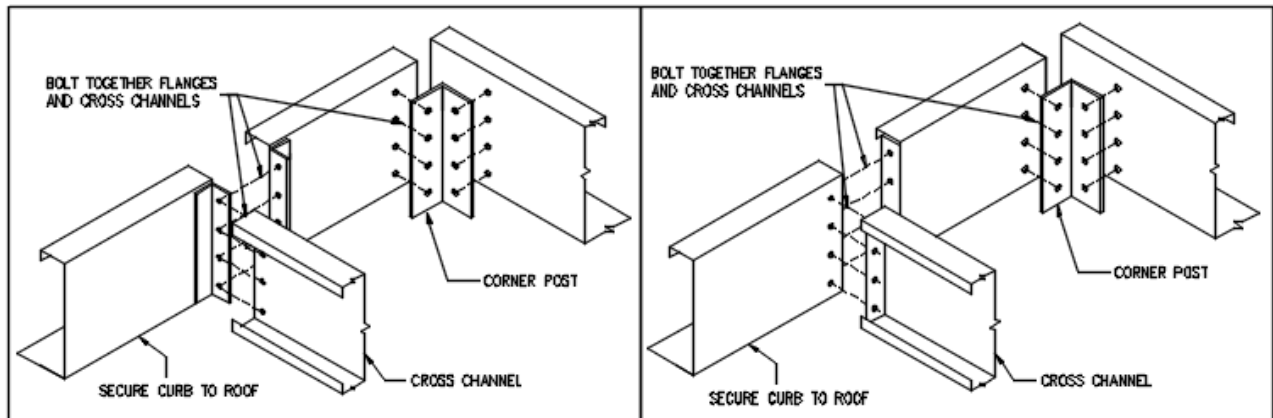

Figure 1: Assembly of Haakon Roof Curb.

- 1) The roof curb ships in pieces; each piece is labeled to match the lay-out drawing to determine the location of each of the pieces. It is important to correctly orient the curb so that cross channels do not interfere with openings in the base of the air-handling unit.
- 2) Bolt the curb together.
- 3) Ensure that the curb mounting surface is level, to within 1/8" over 10 ft. Failure to provide a level mounting surface for the air-handling unit will result in a variety of operational and assembly problems.
- 4) Adequately secure the roof curb to the building structural support in accordance with local building and earthquake codes.

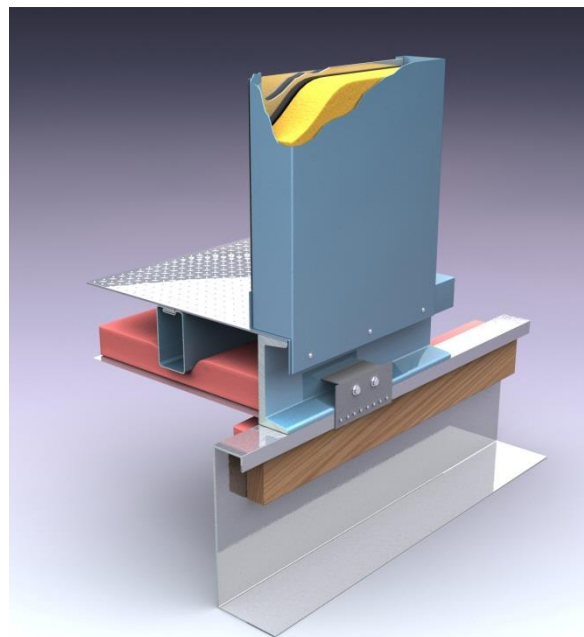

Figure 2: Unit mounted on Roof Curb.

## LIFTING

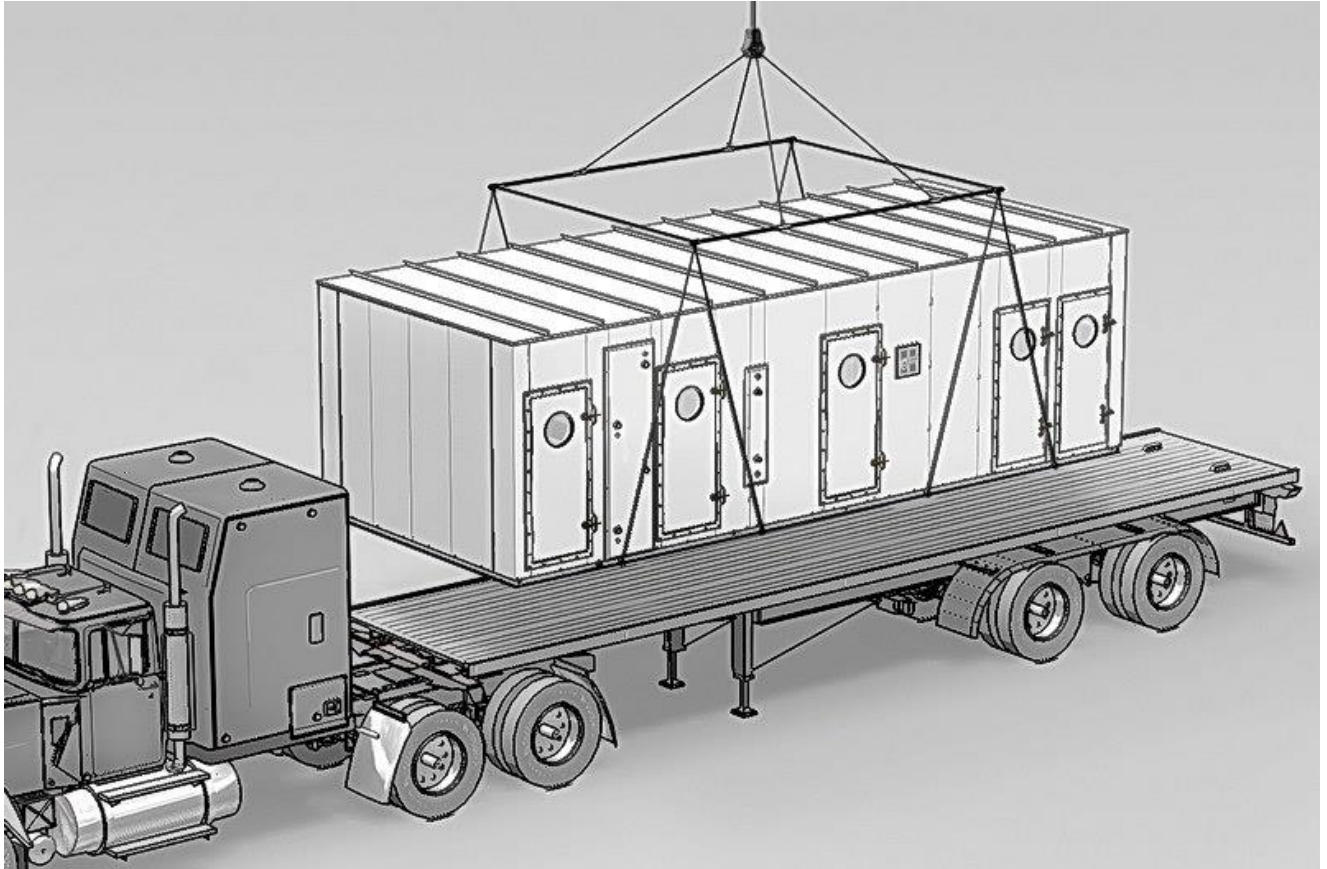

Figure 3: Lifting of a unit with 8 lifting points.

If there are no lifting lugs, use lifting brackets to raise the unit. Be careful to avoid protrusions such as electrical boxes and door handles.

The load distribution in some units may cause them to be unstable when lifted from the base lugs. Use additional slings, or other available means as required, to stabilize the unit during lifting. Always test lift a unit to verify balance and centre of gravity.

Lift the air-handling unit only in an upright position. Never lift or move a unit on its side or upside down.

Failure to properly rig and lift a unit can result in personal injury and property damage.



Figure 4: Lifting of a unit with roof mounted lifting brackets.

## MOUNTING SURFACE

All units (split and non-split) must be mounted on a level surface (within 1/8" every 10 ft). Shims 12" long and the width of the channel may be placed under the base channel to compensate for a non-level mounting surface. Failure to mount on a level surface can result in doors binding,

drains/coils not draining completely or properly and heat pipes not functioning correctly.

For units supported from underneath, the entire foot print including (but not limited to) the perimeter as well as under the unit splits is required to be continuously supported.

## ASSEMBLY OF SPLIT UNIT

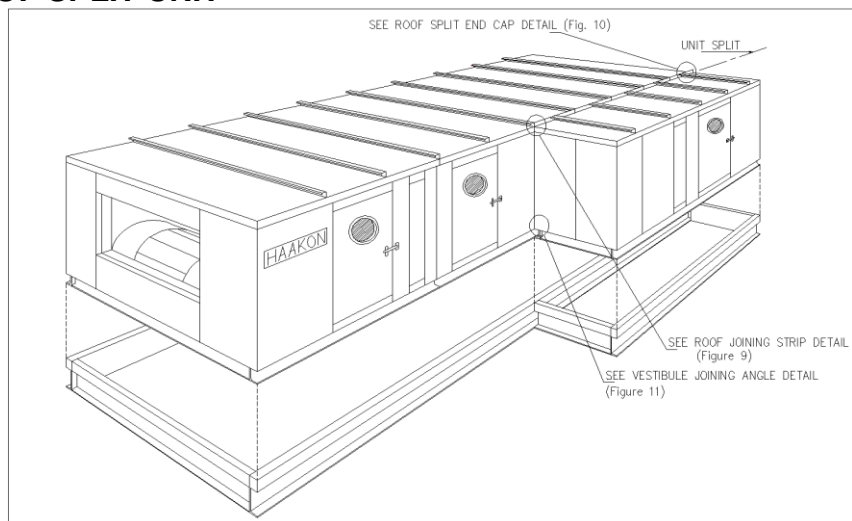

Figure 5: Split Unit.

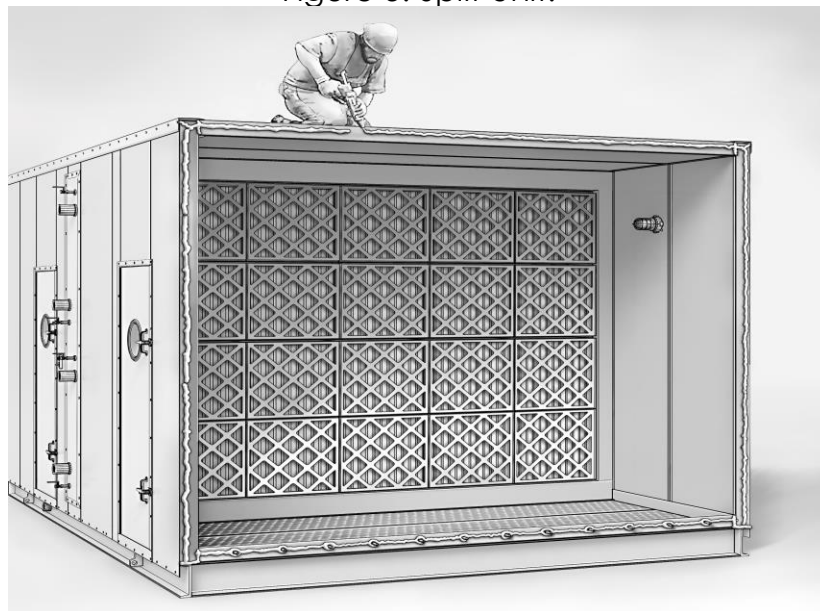

Figure 6: Caulking of Split Unit Joining Surface.

1) Place the first section of the unit in its correct location. Level this section to within 1/8" every 10 ft. See Mounting Surface section for details on leveling.

2) Apply caulking around the facing edges of the casing at the joint (ref. Figure 6) and below the base joining flange holes on both sections.

3) Place the second section adjacent to the first.

4) Attach the units by bolting together the base joining flanges (ref. Figure 7 and Figure 15). If necessary, pull the section together mechanically from the base with a come-along or similar device. Before pulling sections together secure first section to mounting surface. There may be situations, such as in corridors, where flat strips or T-strips are provided instead. Continuously weld flat strips to floor (ref. Figure 8) and continuously caulk T-strips (ref. Figure 9).

5) On split side panels and indoor roof units, secure joining strips to casing (ref. Figure 10 and Figure 11).

6) On split outdoor units, make the roof joint with a capping strip. Apply caulking to the faces of the standing flanges that will come in contact. Position the capping strip over both of the flanges. Screw through the top of the capping strip and the flanges with sheet metal screws on 8 inch centers (ref. Figure 12 and Figure 13).

7) Carefully remove excess caulking which is squeezed from the joints during assembly.

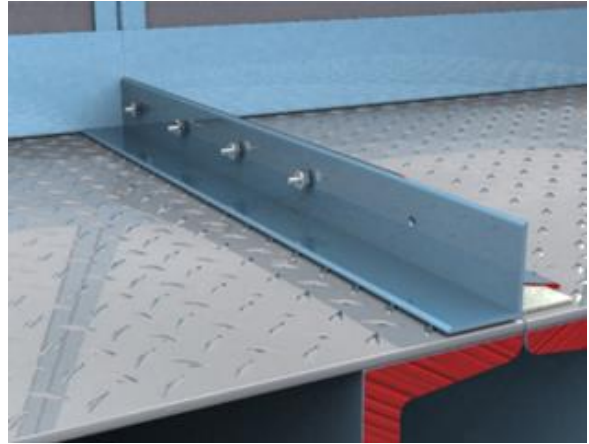

Figure 7: Base Joining Flanges Detail.

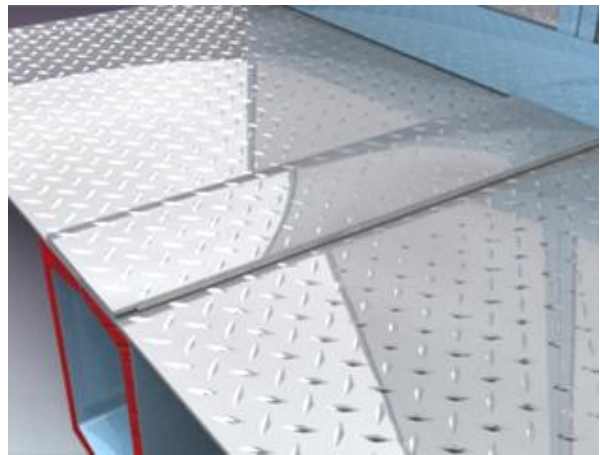

Figure 8: Base Joining Flat Strip Detail.

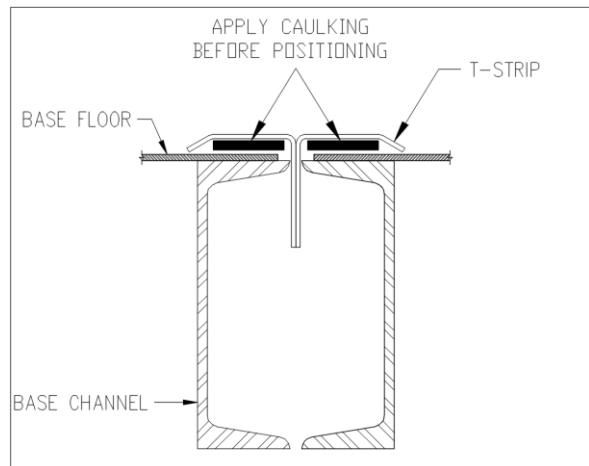

Figure 9: Base joining T-Strip Detail.



Figure 10: Joining Strip Detail.

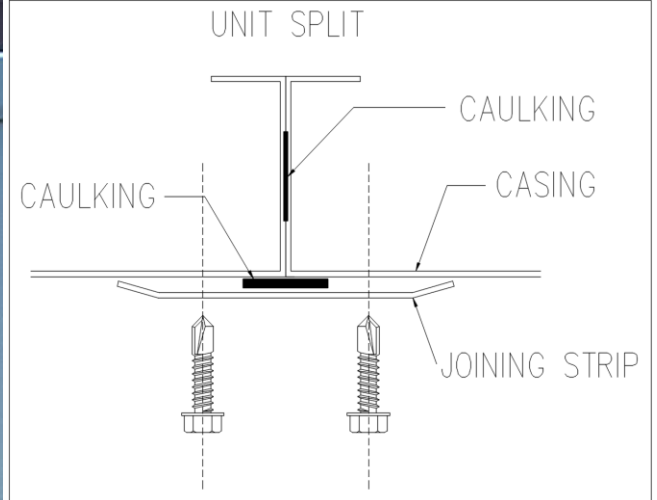

Figure 11: Joining Strip Cross Section.

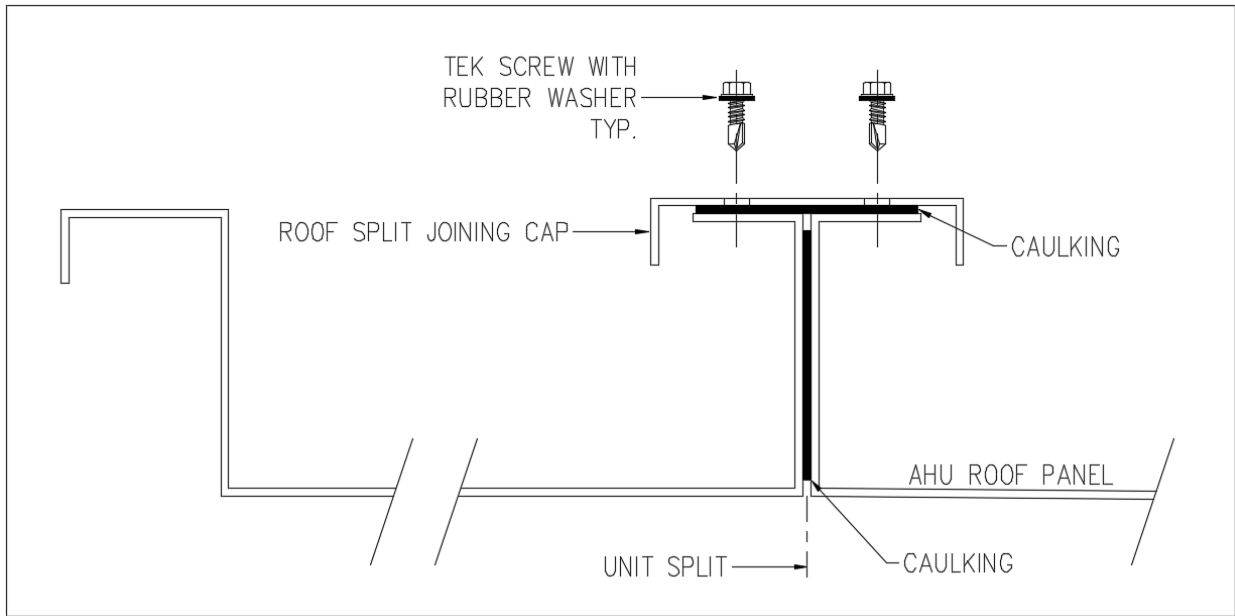

Figure 12: Roof Joining Detail.

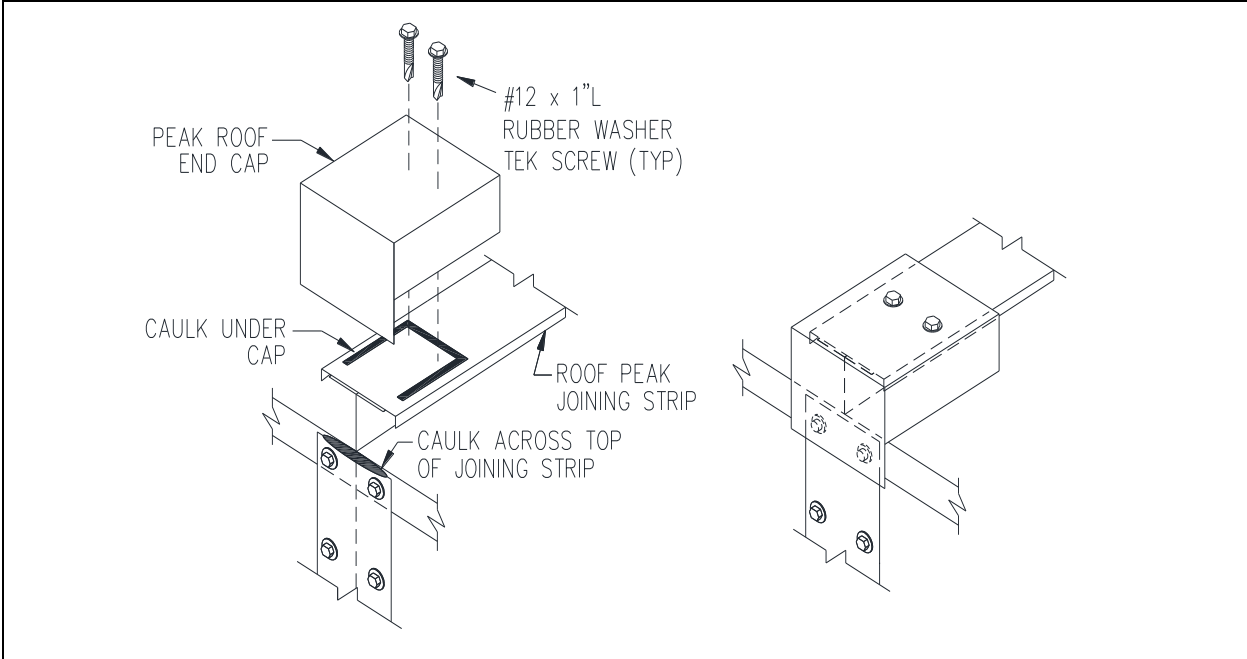

Figure 13: Roof Split End Cap Detail.

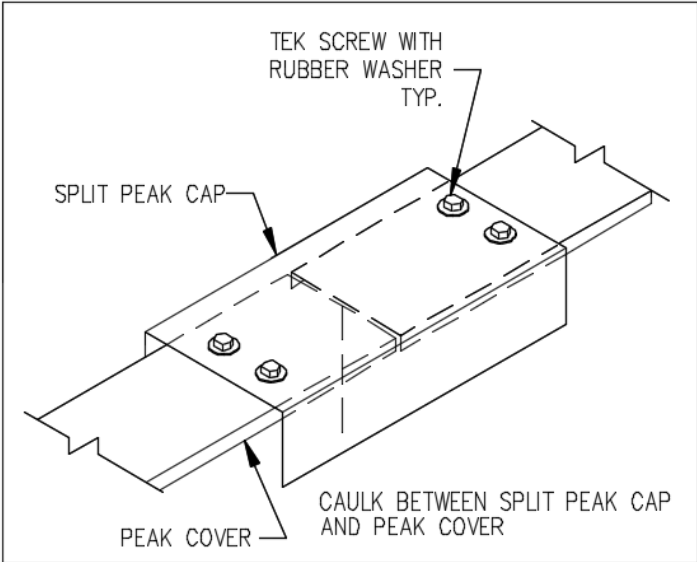

Figure 14: Roof Split Peak Cap Detail.

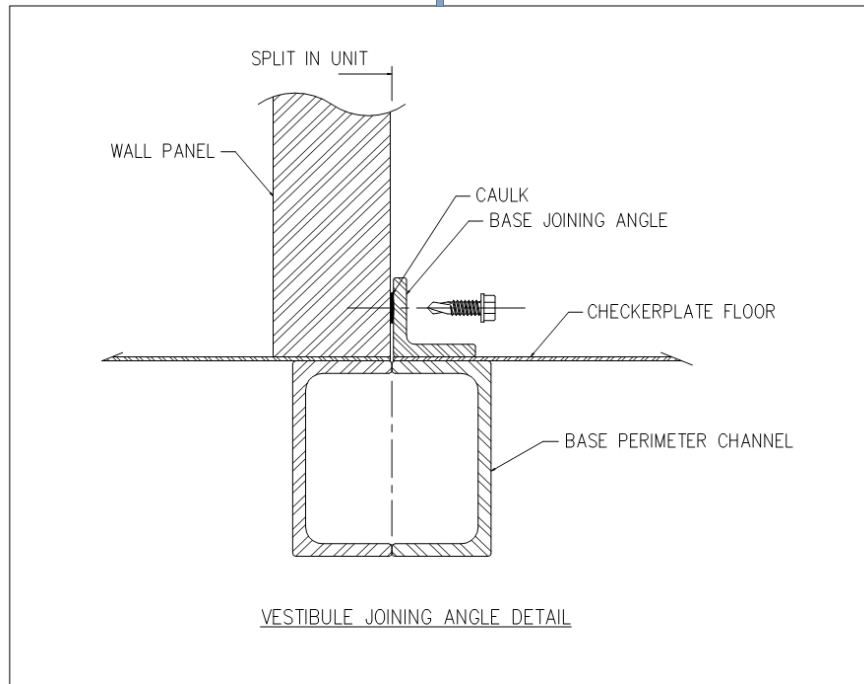

Figure 15: Vestibule/Corridor Joining Angle Detail.

## UNIT INSTALLATION ON A ROOF CURB

1) *Ensure that the roof curb is level.* Level to within 1/8" every 10 ft. Failure to level the curb will result in a variety of operational problems.

2) Check for the correct orientation of the unit on the curb.

3) Check that there is sufficient height between the base of the unit and the roof to allow adequate drain trapping. See Figure 27 for trapping details.

4) Lift the unit into place.

5) Check that the unit is level. Install shims to level the unit as required.

6) Apply caulking to edge between unit base rail and roof curb (ref. Figure 16). Tool in caulk to ensure proper seal. Failure to provide an adequate seal can result in air and water leakage into the building.

7) Haakon roof curbs are provided with unit restraint plates to restrain the unit

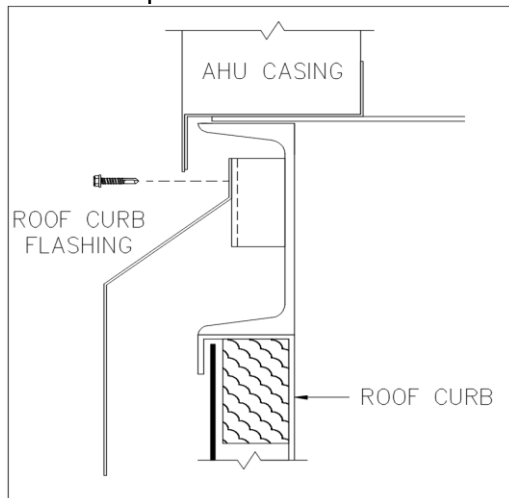

Figure 17: Roof curb flashing cross-section.

horizontally. If the roof curb is not supplied by Haakon Industries, it is the responsibility of the installer to restrain the unit horizontally in accordance with applicable building and earthquake codes.

8) If roof curb flashing is provided see Figure 17 for installation details.

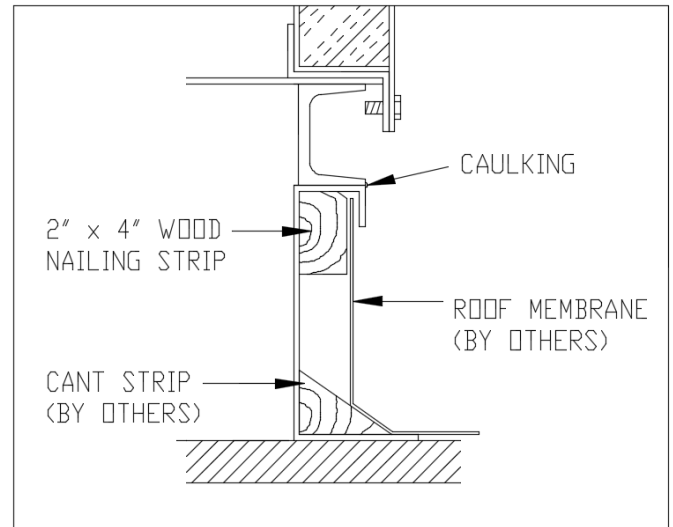

Figure 16: Cross section of Roof Curb.

## ROOF CURB RESTRAINTS

- 1) Install the roof curb and the unit as described in the previous sections.
- 2) Attach restraint plates to *all* the restraint angles welded to the unit base, with the fasteners provided.
- 3) Attach each plate to the roof curb as shown in Figure 18 with 6 self-drilling screws.

**NOTE:** It is the responsibility of the installing contractor to ensure that the roof curb is fixed to the building in accordance with applicable building and earthquake codes.



Figure 18: Curb Restraint Bracket.

## HANGING UNIT INSTALLATION

Support ceiling-hung units from the base using all hanging points provided. The air-handling units are not intended to be

## UNIT INSTALLATION ON HOUSEKEEPING PAD

- 1) The housekeeping pad ***must be level.*** **Level to within 1/8" every 10 ft.** Failure to provide a level mounting surface will result in a variety of operational problems.
- 2) Check that the unit is oriented correctly.
- 3) Verify that there is sufficient height provided between the base of the unit and the floor to allow adequate drain trapping. Alternatively, make a recess in the floor for the drain traps. See Figure 27 for trapping details.
- 4) Lift the unit into place.
- 5) Check that the unit is level. Shim the unit as required.
- 6) Secure the unit to the housekeeping pad. The installer is responsible to secure the unit to the housekeeping pad in accordance with applicable building and earthquake codes.

supported from the casing (ref. Figure 19). The installer is responsible to make the hanging installation in accordance with applicable building and earthquake code.

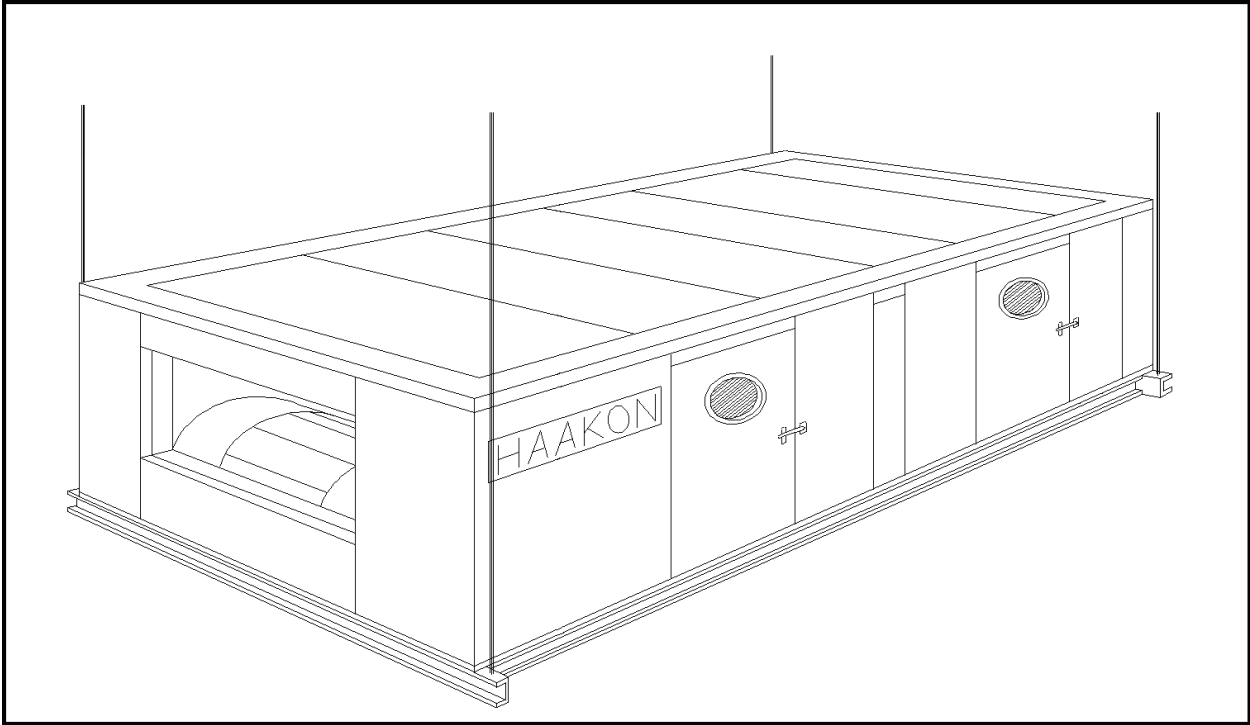

Figure 19: Hanging Unit.

## INSTALLATION OF HOODS

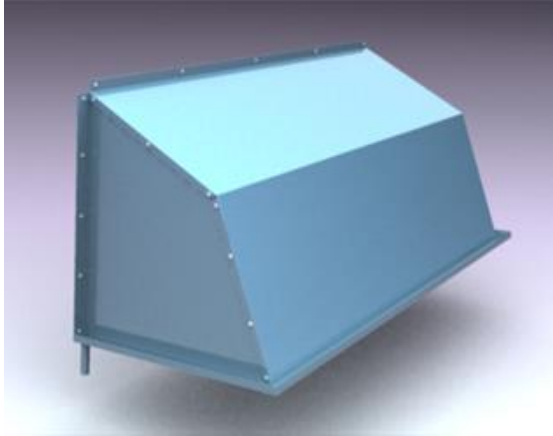

Figure 20: Front view of hood.

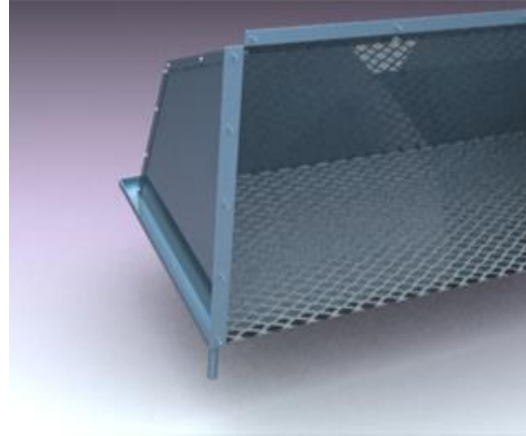

Figure 21: Rear view of hood.

1) Apply caulking to the pre-punched flange of the hood which contacts the unit exterior.

2) Align the hood over the opening, allowing equal coverage on each side, where possible. Check for adequate clearance to doors and other openings of the air handling unit.

3) Secure the hood onto the unit using sheet metal screws through the pre-punched holes on the hood flanges. On openings requiring multiple hoods, install the first hood covering the top of the opening. The lower hoods should fit closely to the upper hood.

4) Carefully remove excess caulking from around the flange of the hood flanges.

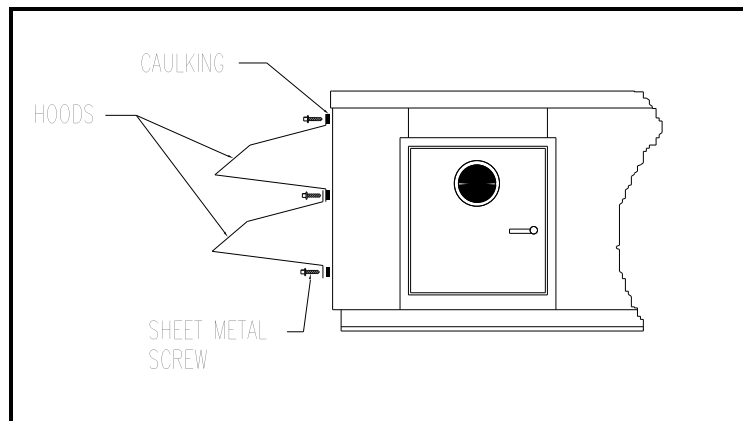

Figure 22: Connection of Hood(s) to Unit.

## SETTING EARTHQUAKE RESTRAINTS

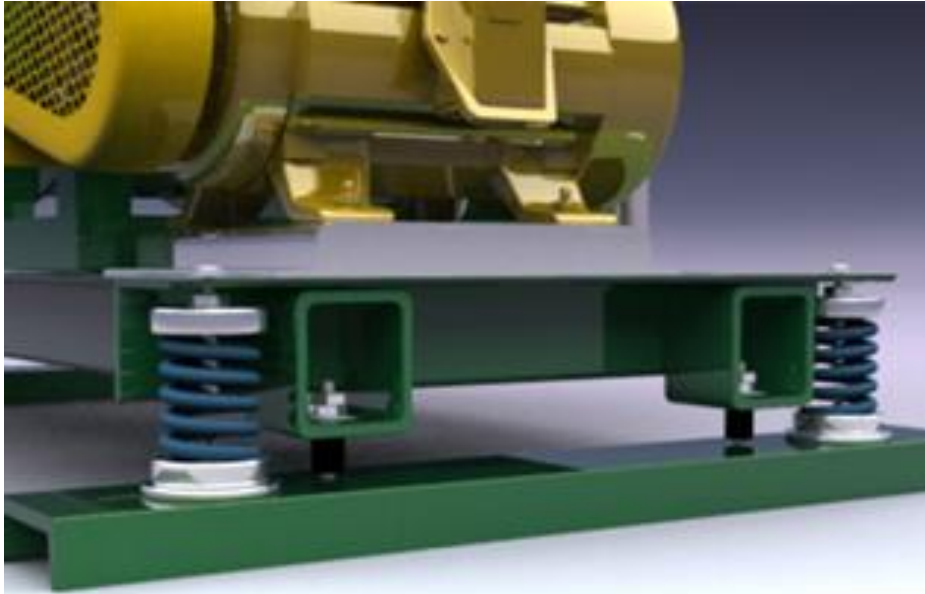

Figure 23: Isolator and Earthquake Restraint.

Before operating the unit, change the earthquake restraints from shipping position to operating position. *Failure to remove the shipping restraints may result in excessive noise and vibration being transmitted to the building.* Failure to properly change the restraint to operating position may result in excessive movements of the fan in the event of an earthquake.

1) Back off the nylock nut until the rubber sleeve is no longer compressed. The nuts and washers must remain installed to provide vertical restraint.

2) Remove and discard the shipping blocks.

3) Once the earthquake restraints have been changed to operating position, the fan should float freely on its isolators. The operating height of the isolators has been set in the factory but adjustments can be made by rotating the top cap of each spring. Adjust the operating height of the entire fan assembly by moving all of the top caps up or down by an equal amount. More weight can be transferred to an individual isolator by moving its top cap downwards. If, for example, one isolator is compressed too much, adjust its top cap upwards and the top caps of adjacent springs downwards (ref. Figure 24)

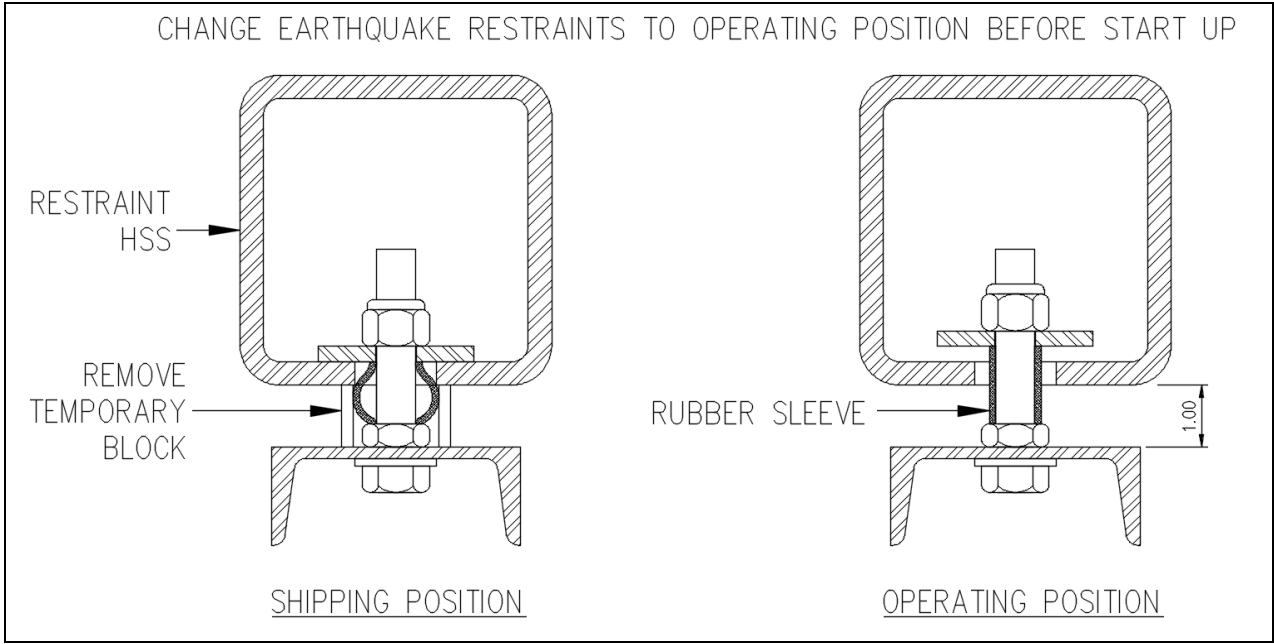

Figure 24: Changing Restraints to Operating Position.

## **SECTION 4: DAMPERS AND DUCTING**

### **DUCT CONNECTIONS**

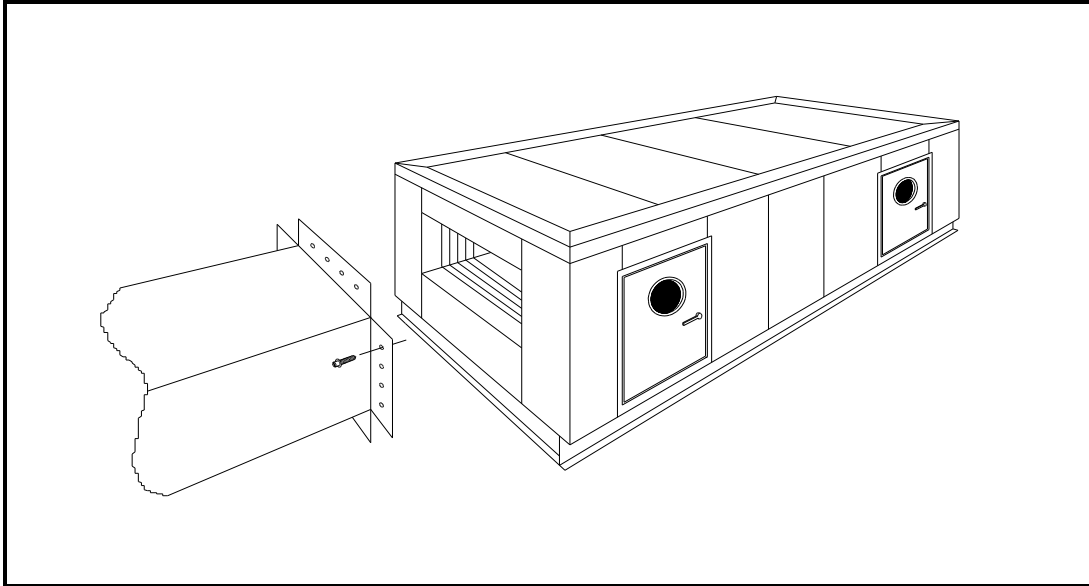

Figure 25: Connection of Duct.

Make duct connections to the casing by screwing flanged ducts directly to the casing with self-tapping sheet metal screws.

Apply caulking around the duct connection. It is important to seal all duct connections to prevent air-leakage and system performance problems.

Duct connections to collar-type openings can be made with s-cleats or overlapping joints.

Exercise caution when installing fasteners to ensure they do not interfere with damper operation.

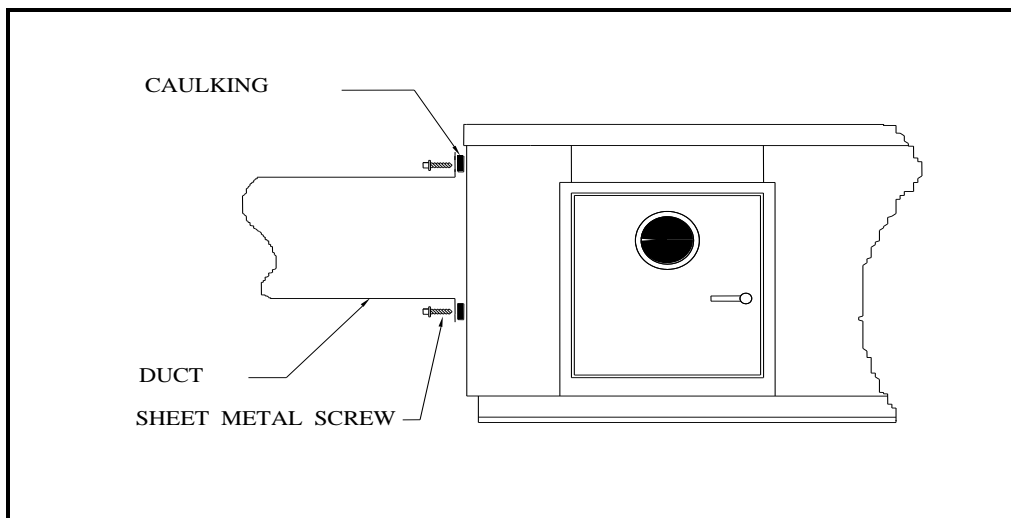

Figure 26: Detail of Duct Connection.

## DAMPER ACTUATORS

Install actuators on the damper drive shaft(s). Where a jack-shaft has been provided, drive the damper from the jack-shaft(s). To obtain proper air-seal and damper operation, the actuator torque should meet the recommendations on the following table.

For standard dampers, the actuator must rotate approximately 95 degrees to move the blades from fully closed to fully open.

## DAMPER TORQUE REQUIREMENTS

DAMPER HEIGHT (in.)	DAMPER WIDTH (in.)								
	12	18	24	30	36	42	48	54	60
12	24	24	24	24	24	24	24	27	30
18	24	24	24	24	26	29	31	34	43
24	24	24	24	28	32	36	40	44	56
30	24	24	30	35	41	47	52	58	69
36	31	31	39	46	53	60	68	75	82
42	30	38	46	54	63	71	79	87	95
48	36	45	54	63	72	81	90	99	108
54	42	52	62	72	82	91	101	111	121
60	48	59	70	81	92	102	113	124	135
66	52	64	76	88	100	112	124	136	148
72	55	68	82	95	108	121	135	148	161

## SEALING TORQUE (in.-lbs.)

Up to 2 in. and 1000 fpm face velocity

Values in Sealing Torque chart (left) reflect the maximum torque requirements up to 2 in. w.c. and /or 1000 fpm face velocity. Refer to Velocity or Pressure Torque charts (below) if system design surpasses criteria of Sealing Torque chart. Base torque requirements on the greatest value obtained.

## VELOCITY TORQUE (in.-lbs.)

@ 1000 fpm face velocity

Multiply value in Velocity Torque chart by the multiplier listed below to obtain torque for greater design face velocity.

FACE VELOCITY (FPM)      MULTIPLIER

1500	2.25
2000	4
2500	6.25
3000	9
3500	12.25
4000	16

DAMPER HEIGHT (in.)	DAMPER WIDTH (in.)								
	12	18	24	30	36	42	48	54	60
12	2	4	5	6	7	8	10	11	12
18	2	4	6	7	8	9	9	10	12
24	4	5	6	8	9	9	11	12	15
30	4	6	7	9	10	12	12	14	18
36	5	7	9	11	13	15	16	18	20
42	6	8	11	12	14	16	18	20	22
48	6	9	12	15	17	19	20	23	25
54	7	10	15	16	18	21	22	25	27
60	7	12	17	18	21	23	25	27	30
66	8	13	18	20	22	24	27	30	32
72	9	15	21	24	26	30	33	36	39

DAMPER HEIGHT (in.)	DAMPER WIDTH (in.)								
	12	18	24	30	36	42	48	54	60
12	2	4	6	7	8	11	12	14	16
18	5	8	12	14	17	19	22	24	31
24	7	12	18	21	25	28	32	35	45
30	10	17	24	27	33	40	44	49	59
36	13	22	33	39	46	52	60	66	73
42	16	27	39	47	56	63	72	79	87
48	18	32	47	57	65	74	83	92	102
54	20	36	55	64	75	85	95	104	116
60	23	42	63	73	86	96	108	119	131
66	24	45	66	79	92	104	116	127	139
72	25	47	72	84	96	108	123	136	150

**PRESSURE TORQUE (in.-lbs.)**

@ 2 in. w.c. differential

Multiply value in Pressure Torque chart by the multiplier listed below to obtain torque for greater design pressure.

DIFFERENTIAL PRESS.	MULTIPLIER
3	1.5
4	2
5	2.5
6	3

**SECTION 5: COILS, DRAINS AND PIPING**

**TRAPPING DRAINS**

All condensate drain connections and floor drains must be trapped. Failure to properly trap a drain will result in flooding of the drain pan and potential water damage to the air-handling unit and other building facilities.

Measure the static pressure inside the drain plenum after the system has been properly balanced. Plenum pressure is measured in inches of water using a manometer. If the fan has variable inlet vanes or a VFD, measure at the peak pressure.

As an alternative to measuring the actual pressure, the maximum static pressure listed on the unit nameplate can be used as a conservative estimate of the plenum pressure. Determine the required dimensions of the trap from the following diagram.

Since the condensate is drained only by the force of gravity, avoid long runs of drain piping. If a long run of trap piping cannot be avoided or the piping has water flow restrictions such as several elbows, add extra height to H1 to provide enough hydrostatic head to overcome the frictional losses.

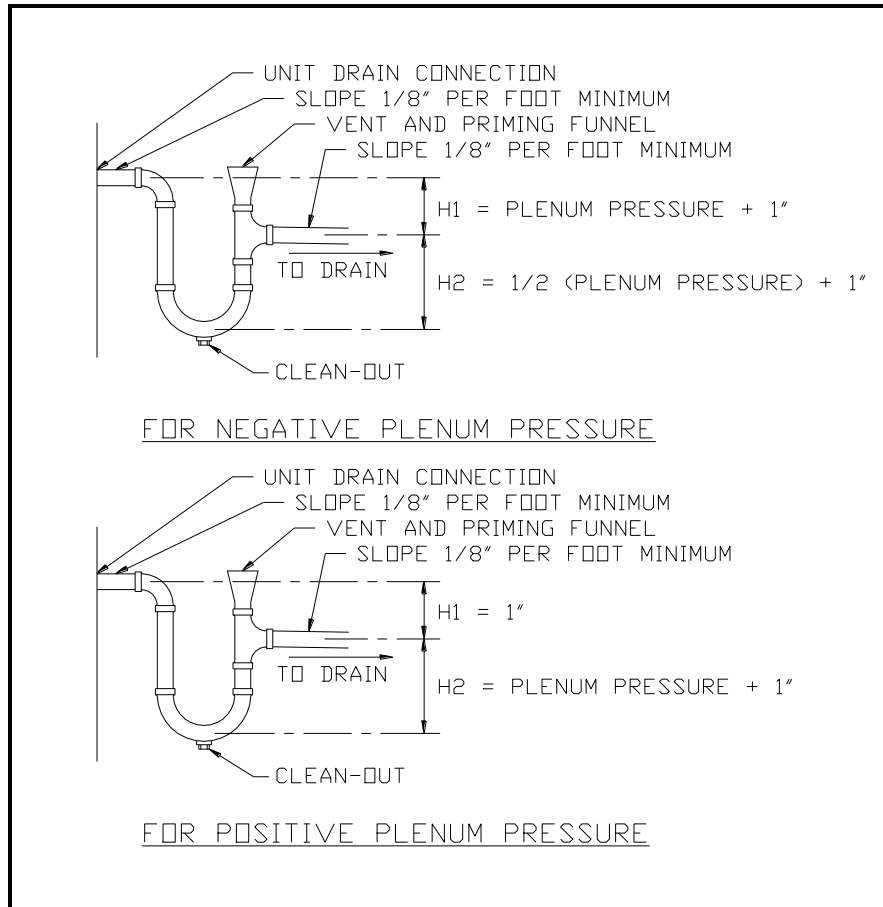

Figure 27: Trapping Dimensions.

Always slope condensate piping in accordance with the national and local piping codes.

The discharge of the trap must be at atmospheric pressure and not tied into a pressurized line or the trap will not function properly.

Never attach two drain connections from an air-handling unit into a common trap. This practice will result in water draining from one compartment into the other.

Never attach drain piping to a closed drain or sewer gasses may enter the air stream through the drain.

To function properly, a trap must always be primed. The "U" portion of the trap must be filled with water. If the trap is not properly primed, air will be drawn through the trap upon start-up and prevent proper condensate drainage.

Drains which are inactive will dry out and air will be drawn through the drain preventing water flow. Inactive drains should be plugged or connected to a shut-off valve.

On outdoor units, drain and cap the traps during periods in which freezing temperatures may occur; during this time, the drain must be inactive. An alternative for drains which are active during the freezing season is to install a heat-trace around the trap piping.

Traps on outdoor units should be heated to prevent them from freezing during cold weather. Inactive drains may be drained and capped until required for the start of the cooling season.

## COIL PIPING CONNECTIONS

Connection of piping to air handling units should only be performed by qualified mechanics. The following general guidelines should be used when connecting piping to the air handling unit:

- 1) Support all coil piping independently of the coils to avoid placing excessive stress on the coil headers.
- 2) Consider the thermal expansion effects when installing piping on heating coils. Swing joints or flexible fittings should be used to absorb thermal strains.
- 3) Connect the piping to the coil only tight enough to prevent leakage.
- 4) Be particularly cautious about over-tightening the piping into the coils when elbows or flanges are mated to the nipple which is entering the coil.
- 5) *Always use a back-up wrench when attaching piping to coils.* Failure to use a back-up wrench may result in damage to the coil header.
- 6) Never use Teflon tape on piping being installed in the coil headers. Teflon tape reduces the friction and increases the tendency to over-tighten the piping and cause damage to the coil headers.
- 7) Always drain water from coils which will be exposed to freezing air temperatures when not in use. As complete drainage by gravity is unlikely, use compressed air to force out any remaining water or fill the coil with a glycol mixture to prevent freezing of the coil.
- 8) Always seal between the unit casing and the entering piping before the pipe is insulated. Failure to provide an air seal

may cause capacity problems or sweating inside the unit.

- 9) When installing coil piping, always check that the piping will not interfere with access doors into the unit.

## FACTORY SUPPLIED PIPING

Check piping to ensure there has been no shifting or damage during shipping and that there are no leaks at any fittings or piping components. All piping systems should be pressure tested prior to insulating and start-up.

## WATER COIL PIPING

- 1) Install an air vent in the top plug tapping of the supply or return header. If the supply or return line rises above the top of the coil, provide an air vent at the top of the supply or return line.
- 2) On coil supply lines, make provision to drain the coil.
- 3) When connecting steel to copper coil headers, use a brass or dielectric pipe nipple between the steel pipe and copper header to prevent galvanic corrosion.

## STEAM COIL PIPING

- 1) Always install vacuum breakers on steam coils to prevent collapse of the coil under low heating loads. On coils provided with an unused condensate return tapping, install the vacuum breaker onto the tapping as close to the coil as possible. On all other steam coils, tee the vacuum breaker off of the supply piping as near as possible to the supply connection. The vacuum breaker should be vented to the atmosphere or connected into the return main at the discharge of the steam trap.

2) It is important to allow condensate to flow freely from the steam coil. Failure to provide adequate means for condensate removal may result in: water hammer, thermal stresses, freeze-up, or corrosion. As a result, proper steam trap selection and application are very important.

3) Each coil should have its own steam trap. Headers that are designed to expand during operation should be positioned to allow expansion when piping is connected.

4) Steam traps should be sized for the maximum possible condensate flow rate with a service factor of 2 to allow for morning warm-up.

5) The capacity of a steam trap is dependent on the amount of head between the return connection on the coil and the trap. Consult the trap manufacturer's literature to determine the required amount of head above the trap. Usually the steam trap should be located at least 12 inches below the condensate coil connection. This is to provide enough hydro-static pressure to overcome trap losses and maintain adequate condensate flow.

6) Float and thermostatic (F&T) traps are recommended for applications where the steam pressure is modulated or is less than 15 psig. Inverted bucket traps are recommended for steam pressures above 15 psig.

7) Provide an inlet strainer for each steam trap to prevent fouling of the trap.

8) The steam supply valve should always be opened gradually to prevent sudden movement of condensate in the pipes and potential coil damage. Modulating valves should have gradual modulating action.

9) Systems with overhead or pressurized returns should not be modulated unless the condensate is drained by gravity to a receiver which is vented to the atmosphere.

10) All steam piping should be pitched a minimum of 1 inch per 10 feet in the direction of flow to promote positive drainage.

11) Pre heat coil before opening fresh air dampers.

12) To avoid capacity problems associated with condensate inside the coil, the condensate in the steam mains should not be drained through the coils but rather through a separate steam trap directly to the condensate return lines.

## **REFRIGERANT PIPING**

Installation of refrigerant piping should only be performed by a qualified mechanic.

1) An externally equalized TEV (thermostatic expansion valve) should be placed close to the evaporator coil distributor. It should be sized for the full range of refrigerant flows which will be present in the line. Flow rates may vary depending on the application. The suction sensing bulb should be located as close as possible to the suction connection of the evaporator coil. The external equalizer line should be downstream of the bulb.

2) A pressure tap should be installed on the suction line near the TEV sensing bulb to allow setting of the TEV superheat.

3) Before start-up, leak-check all refrigeration components. During initial set-up or maintenance of the refrigeration system, never discharge any refrigerant into the atmosphere. Refrigeration should always be recovered and either recycled or properly disposed of to prevent ozone depletion.

## EVAPORATIVE HUMIDIFIER

### **INSTALLATION:**

The evaporative media must be installed so that the steeper flute angle slopes down towards the air entering side as shown in Figure 29. This delivers more water to the

hot, dry, dirty side where it is needed most and also prevents water carryover by counteracting the tendency of the air to push the water out the air leaving side.

### **RECIRCULATING SYSTEM:**

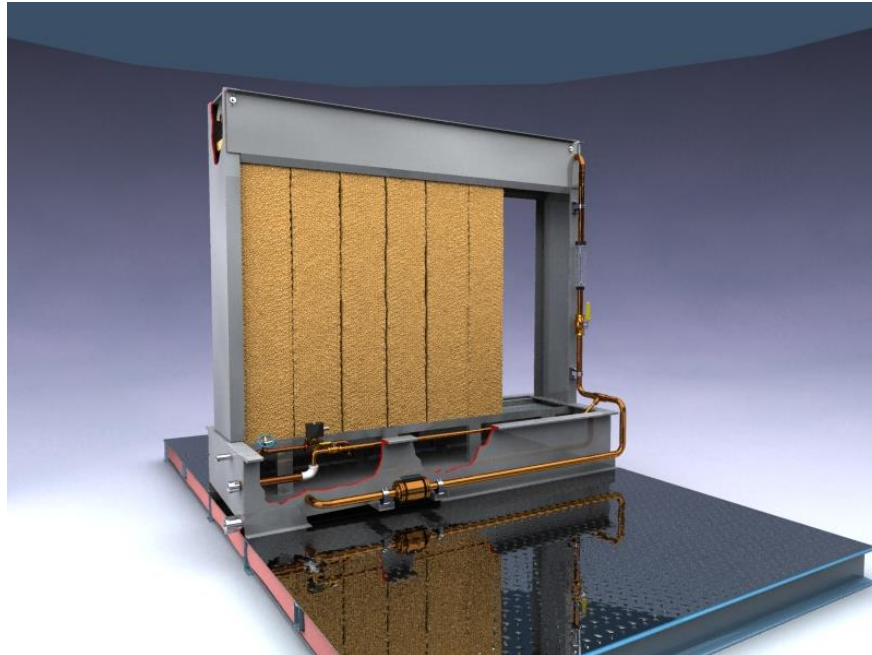

Figure 28: Evaporative Humidifier.

There should be no visible gaps in the media pieces.

1) The water flow to the media should be adjusted so the media is just saturated. Starting with 1.5 gpm per sqft of top media area, set the flow rate at 100% air flow with design relative humidity. The water distribution should be even across the entire evap with no dry or extra wet sections. Too low a flow rate will result in poor performance and a build up of mineral deposits in the pads. If the flow rate is too high, water carryover and splashing will occur. To prevent scale formation, 3-6% of the re-circulated water should be bled off to control the concentration of minerals and other impurities in the re-circulated water.

The bleed-off is controlled by a ball valve and is connected to the overflow drain.

2) A make-up water connection is required to replace both the water that is bled off and that which is evaporated into the air stream. When setting the water level in the tank is important to remember that when the evap is in operation and the water is circulating, the tank should not be full. Otherwise, when the evap is shut off and the water drains from the media it will cause the tank to overflow. The water level in the tank, during operation, must be above the pump intake.

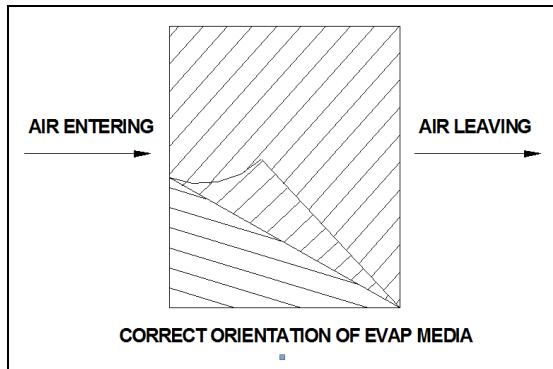

Figure 29: Media Cross Section.

3) The overflow prevents flooding of the evap tank in the event of a loss of power or the circumstances described above. The overflow must be trapped and piped to a drain. See the section on “Trapping Drains” for more details.

4) The tank drain allows the system to be completely drained for cleaning and seasonal maintenance. Typically a ball valve is installed on the drain to allow manual operation. The tank drain may be piped into the same trap and drain as the overflow as long as the connection to the overflow piping is made downstream of the ball valve.

#### **SINGLE PASS SYSTEM:**

1) The water flow to the media should be adjusted so the media is just saturated. Starting with 1.5 gpm per sqft of top media area, set the flow rate at 100% air flow with design relative humidity. The water distribution should be even across the entire evap with no dry or extra wet sections. Too low a flow rate will result in poor performance and a build up of mineral deposits in the pads. If the flow rate is too high, water carryover and splashing will occur.

2) The drain must be trapped and piped to a drain. See the section on “Trapping Drains” for more details.

#### **MAINTENANCE:**

1) Pads should be allowed to dry out completely every 24 hours to prevent algae growth.

2) The entire water distribution system should be drained and disinfected at least four times per year.

3) Ensure that any water treatment chemicals are suitable for use with the evap media.

4) Clean any water filters regularly.

5) If there are scale or mineral deposits forming on the face of the media, the mineral content in the water is too high. Solutions would be: to increase the flow of water over the face of the media; clean and flush the distribution pipe on top of the media; check the pH of water (which should be between 6 and 8); and use plenty of bleed-off.

6) Replacement of media will depend on usage. However, once the media is noticeably fouled or damaged, it is best to replace the media. Damaged media may cause the water to be carried downstream in the unit.

#### **ELECTRICAL CONNECTIONS:**

All electrical connections must be made by a qualified electrician.

For units furnished without motor wiring, the wiring must be supplied by the installer and comply with applicable electrical codes as specified by the jurisdiction having authority. The wiring and electrical components must be adequate for the service listed on the motor nameplate.

Where the motor wiring has been factory installed, connect the power wiring to the appropriate terminals as shown by the electrical schematic supplied with the unit.

Often, units are provided with more than one electrical supply point; more than one disconnect switch may be required to disconnect the power for servicing.

The wiring and electrical components must be adequate for the service listed on the unit electrical data nameplate(s). If main disconnect switches have not been factory

installed, the installer must provide a switch to disconnect power from each supply point on the unit.

Where motor starters or variable frequency drives have not been factory-installed, overload and over-current protective devices must be provided for each motor in accordance with the local electrical codes.

## SECTION 6: ELECTRICAL CONNECTIONS

### **INSTRUCTIONS FOR WALL PANEL ELECTRICAL PENETRATION FOR FIELD POWER WIRING**

Instructions for power wiring penetration into the air section of the unit in the case where the customer desires to provide field wiring directly to a motor inside our air handling unit. All parts and tools required are standard electrical items.

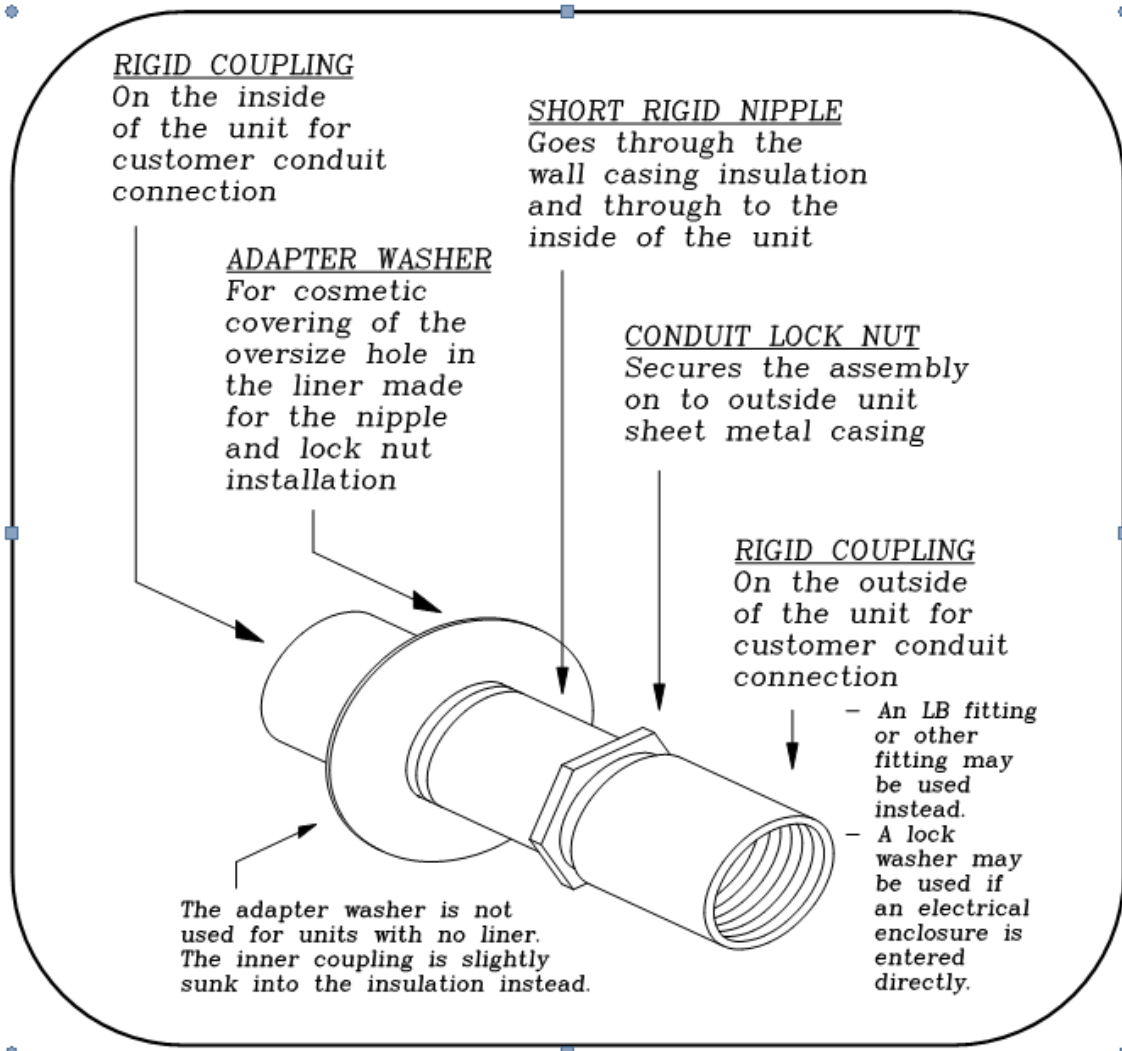

Figure 30: Electrical Fittings.

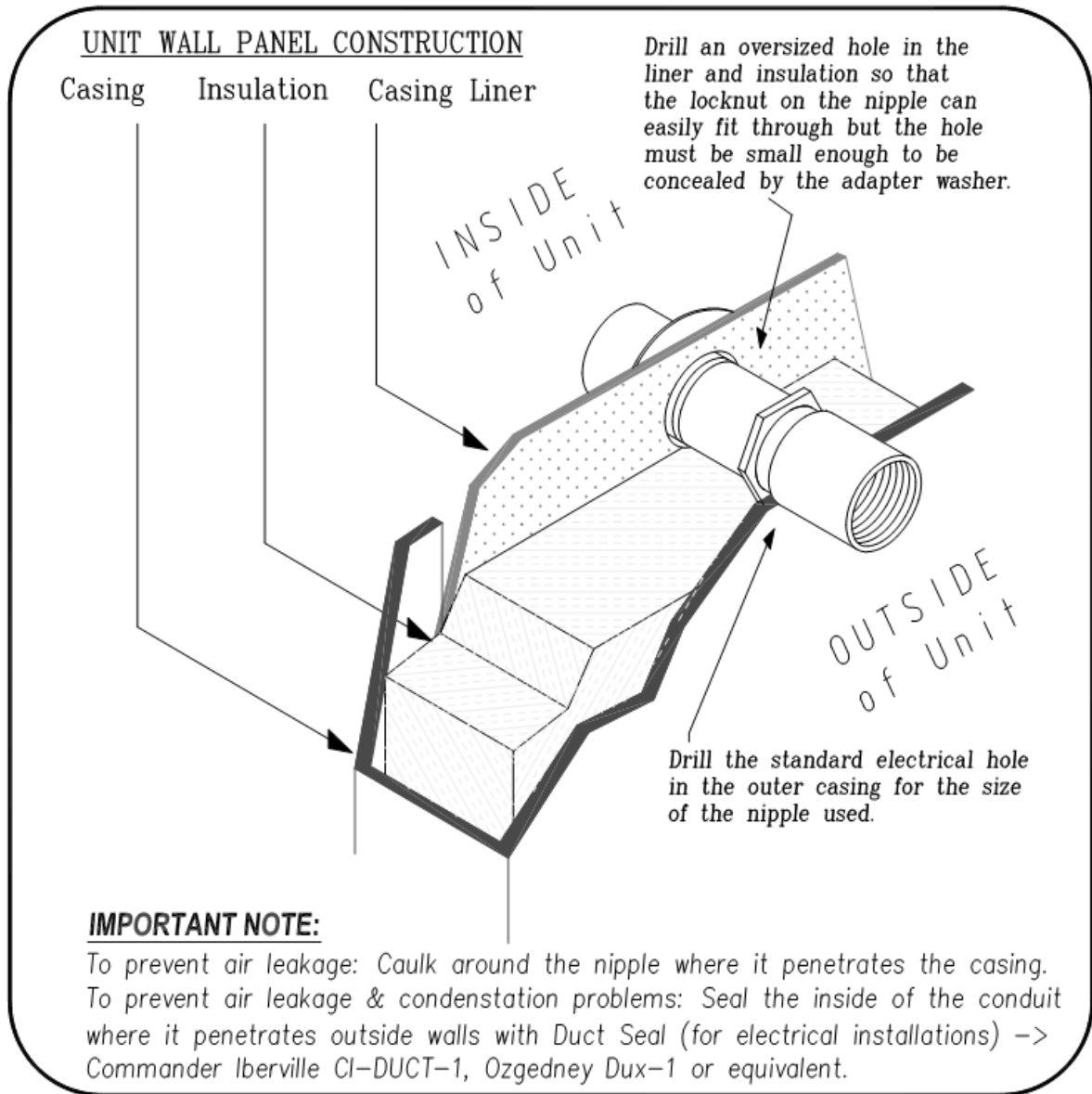

Figure 31: Electrical Penetration Detail.

## **SECTION 7: FILTERS**

### **FILTER INSTALLATION**

The diagrams on the following pages show the installation procedure for various air filters and holding frames. The list of applicable diagrams is shown below:

#### **FILTER COMBINATION**

Filter Frame Detail	Figure 32
Final Filter Upstream Installation	Figure 33
Pre-filters and Final Filters in Common Holding Frames (Upstream)	Figure 34
Pre-filters and Final Filters in Common Holding Frames (Downstream) with spacer for separate pre and final filter gauges	Figure 35
Pre-filters and Final Filters in Common Holding Frames (Downstream)	Figure 36
Final Filter Downstream Installation	Figure 37
Lift-out Pre-filter Installation	Figure 38
Slide-out Pre-filter Installation	Figure 39
Slide-out Pre-filter and Final Filter in a Common Rack	Figure 40
Slide-out Final Filter Installation	Figure 41
Lift-out Angle Filter Installation	Figure 42
Lift-out HEPA Filter Installation	Figure 43

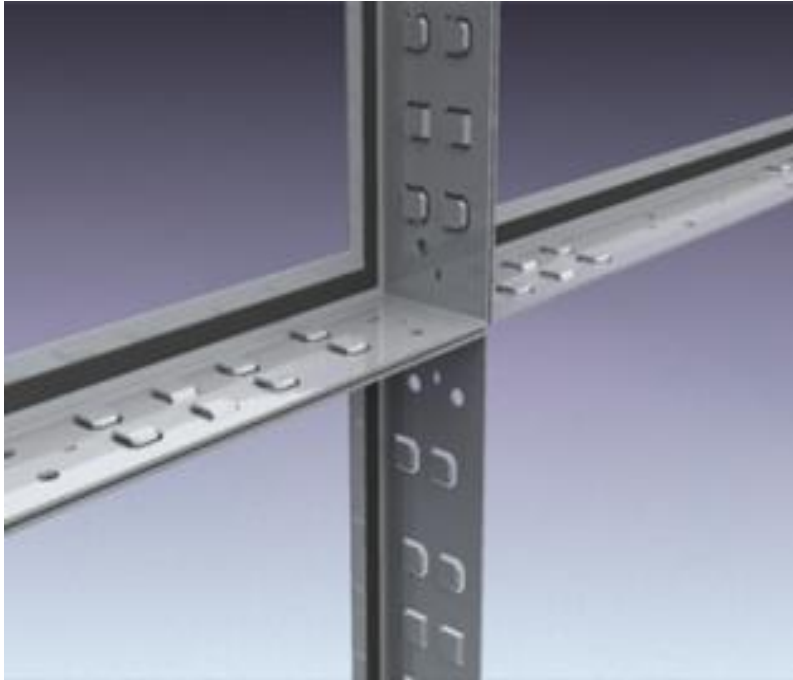

Figure 32: Filter Holding Frames.

The filter frame gasket material should be inspected when filters are installed and repaired or replaced when required in order to maintain the integrity of the seal.

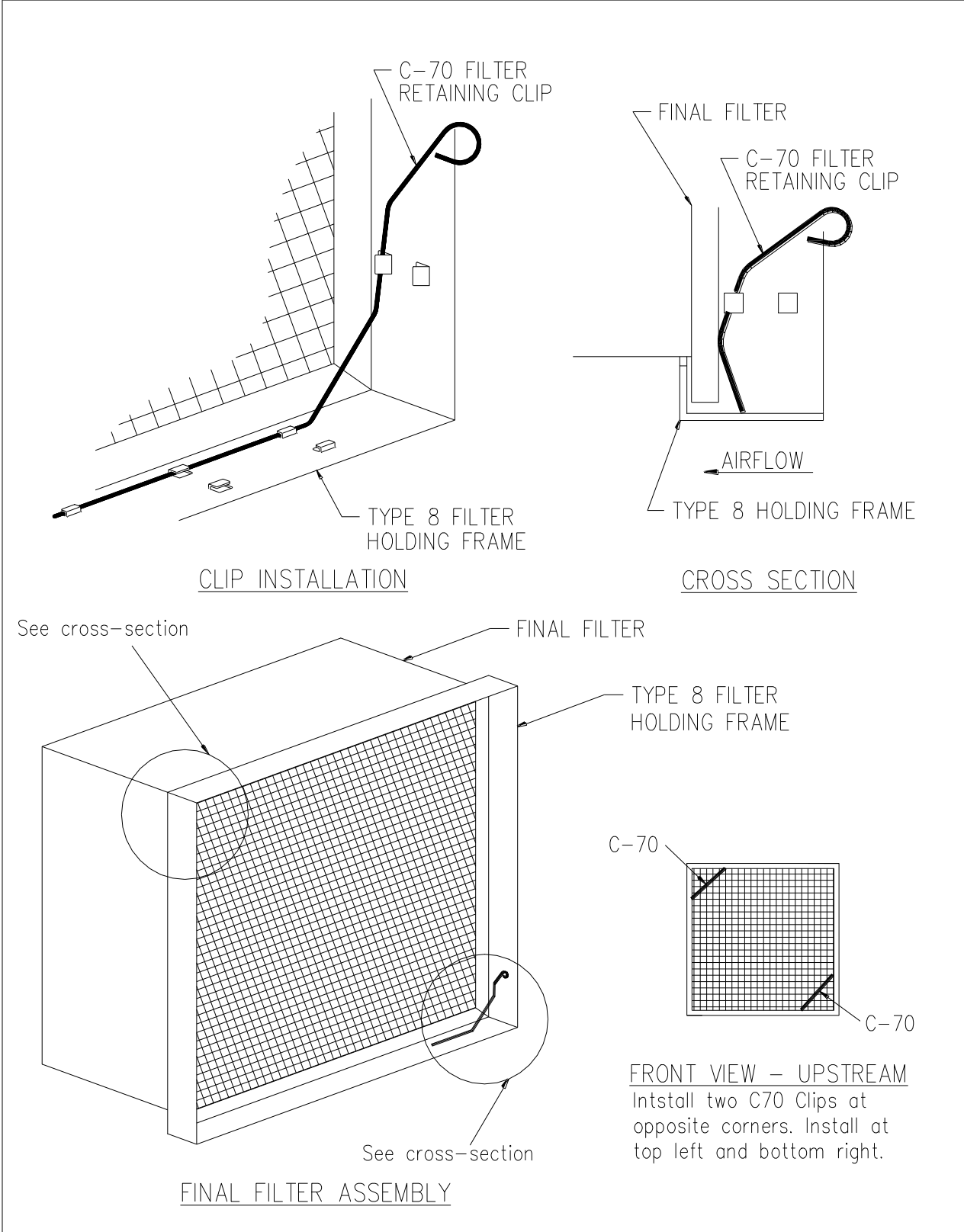

Figure 33: PH Style Final Filter Upstream Installation in Holding Frame.

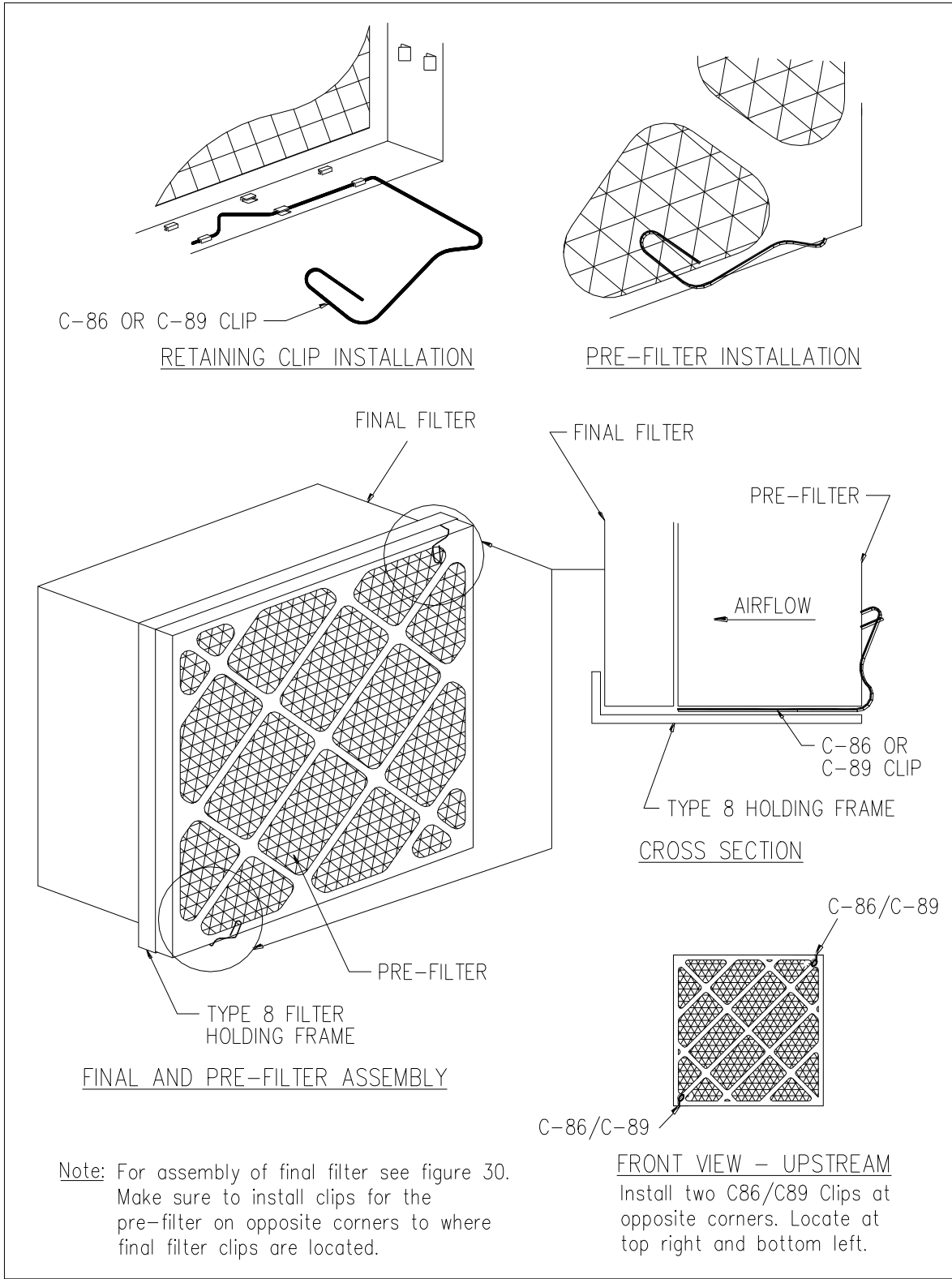

Figure 34: Pre-Filter & Peripheral Headered(PH) Final Filter in Common Holding Frame.

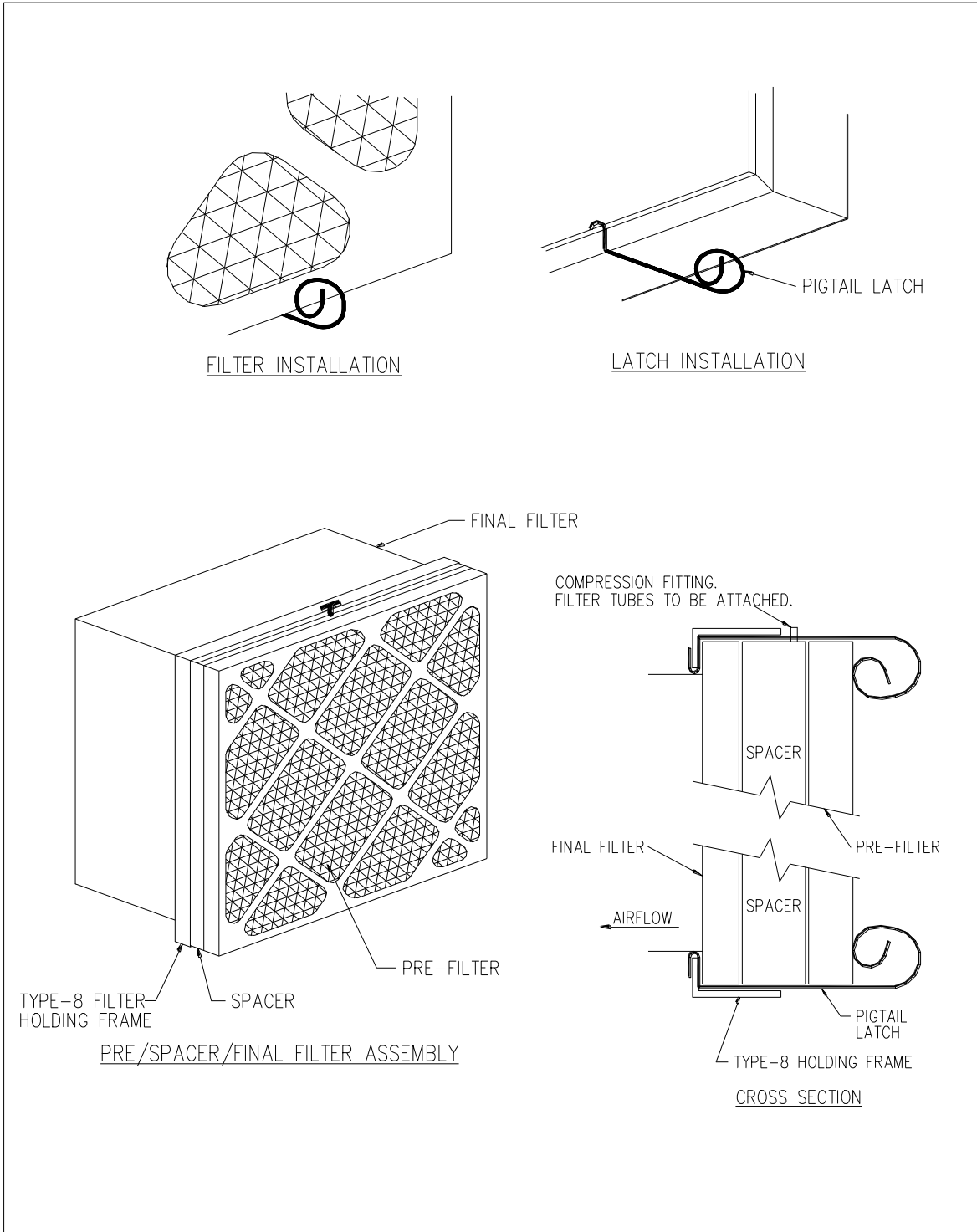

Figure 35: Pre-Filter and Peripheral Headered (PH) Final Filter in Common Holding Frame with spacer for separate pre and final filter gauge installation.

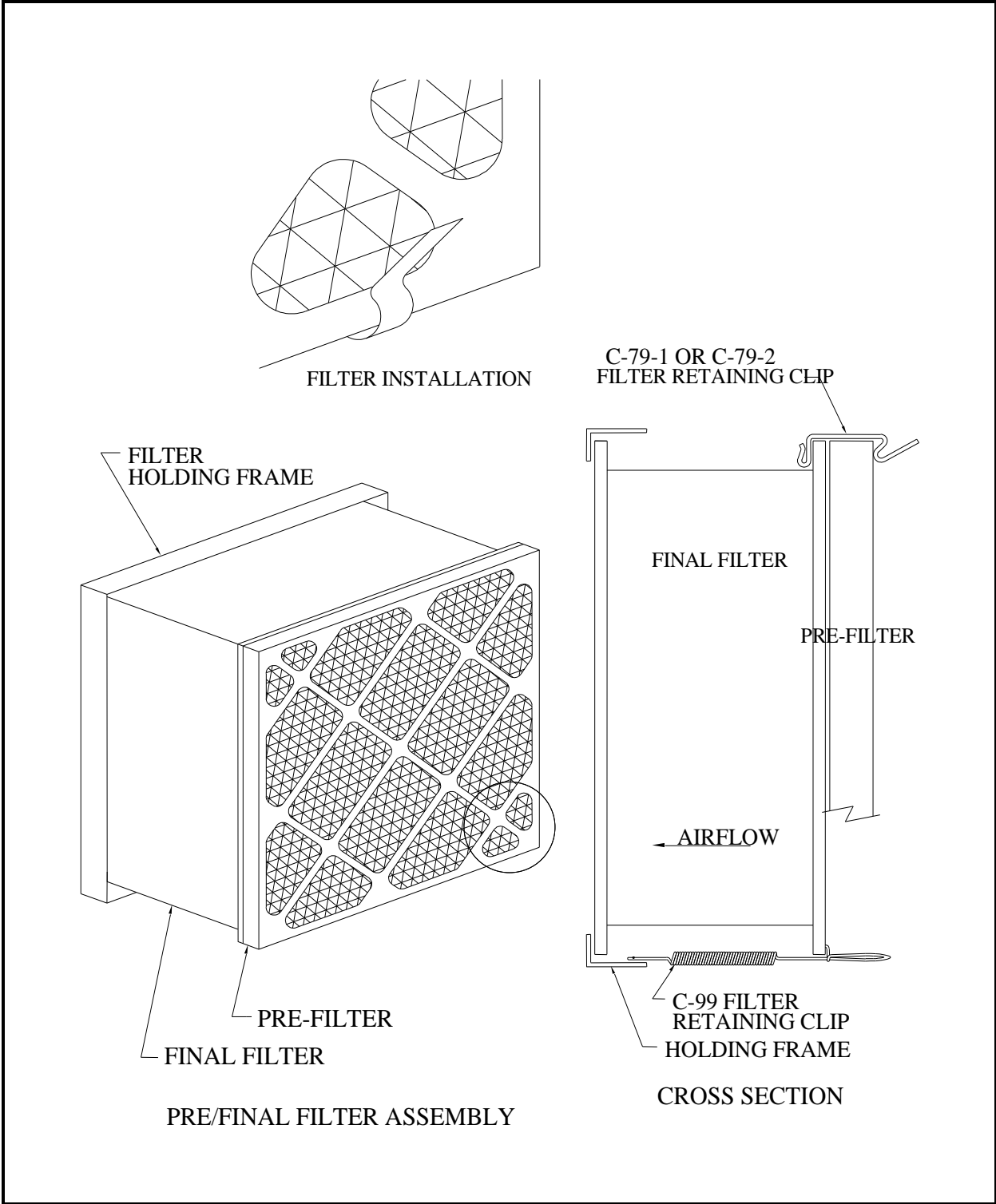

Figure 36: Upstream Pre-Filters and Final Filters in a Frame Downstream of Filters.

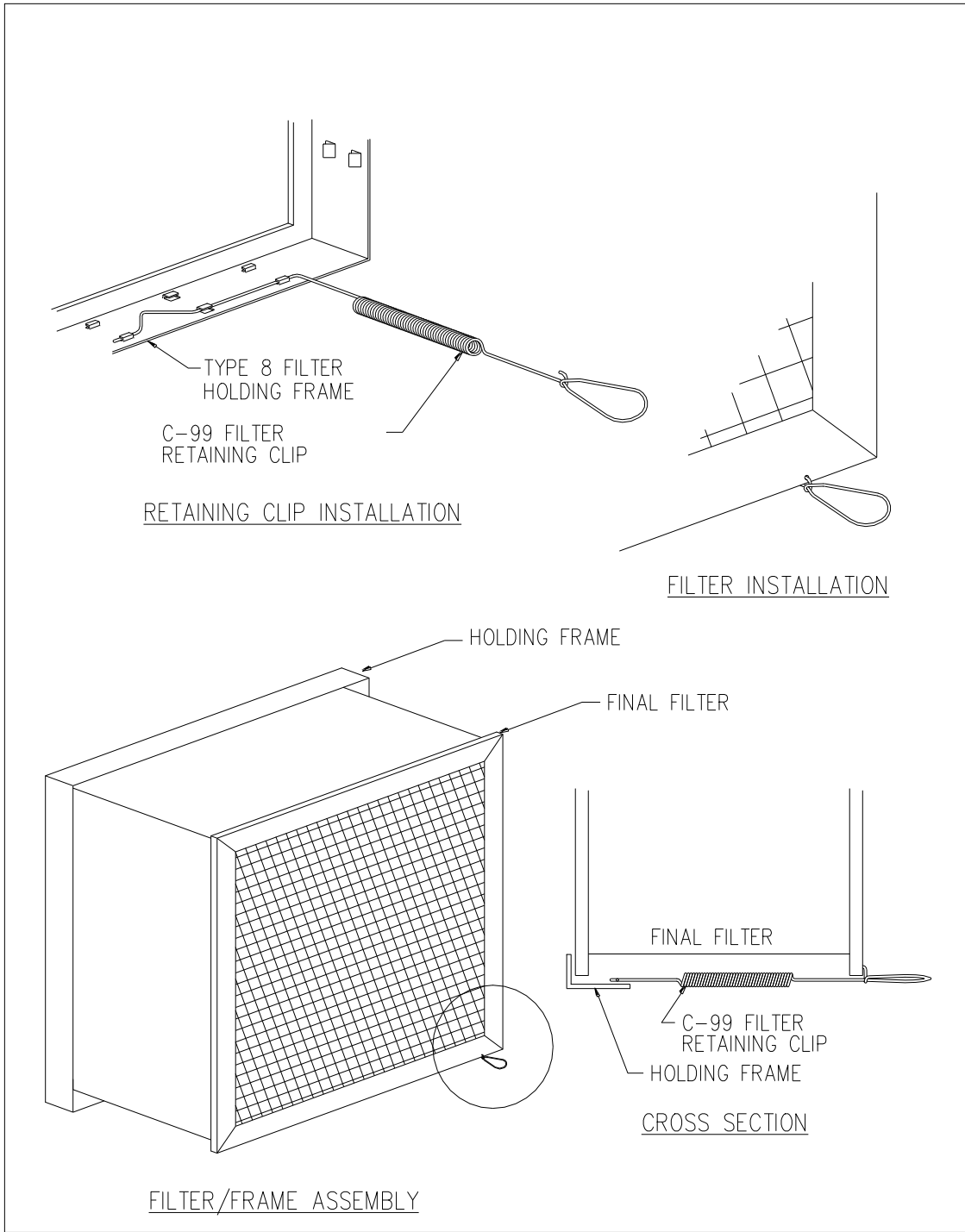

Figure 37: Downstream Lift-Out Final Filter Installation in Holding Frame.

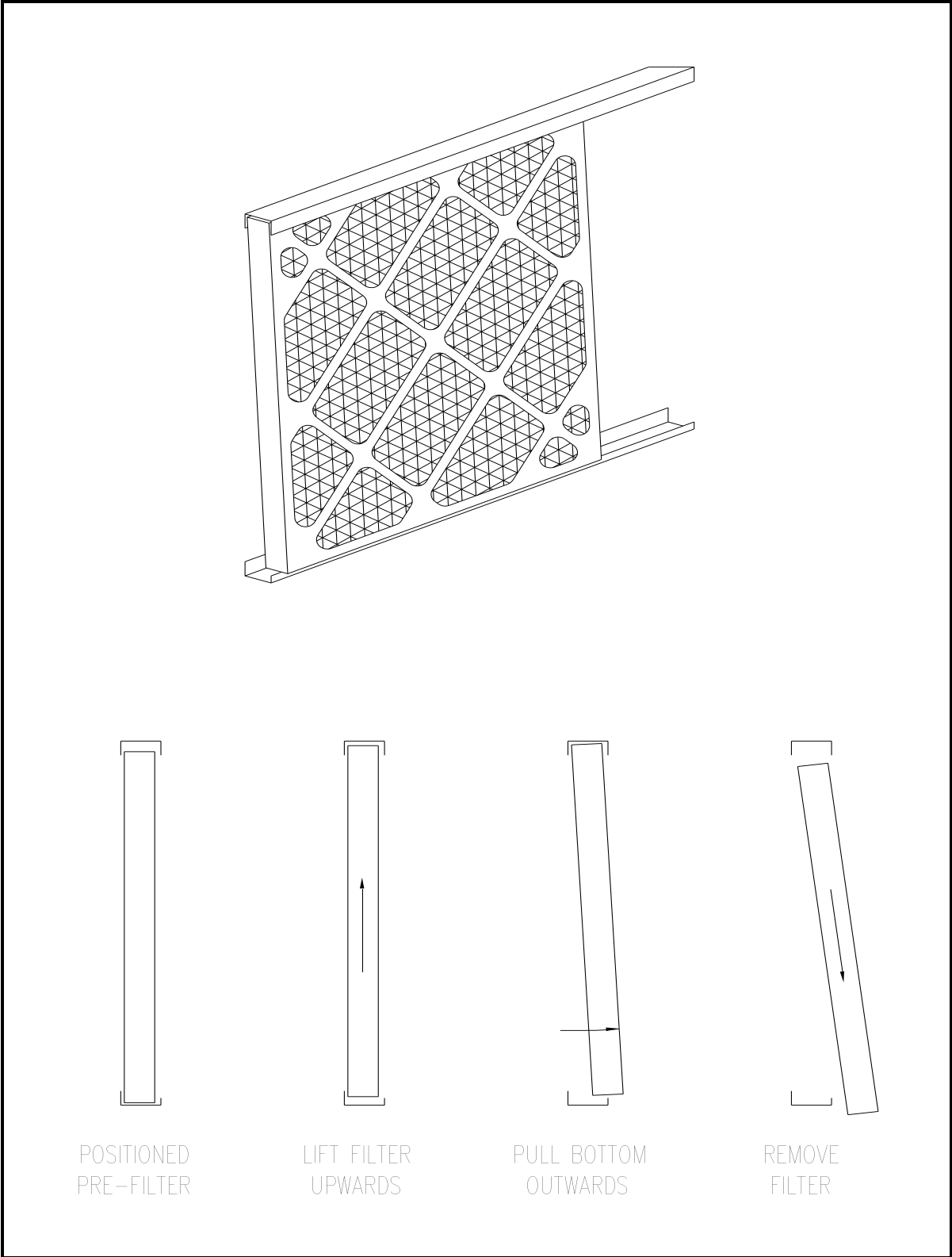

Figure 38: Lift-Out Pre-Filter Rack Filter Access Sequence.

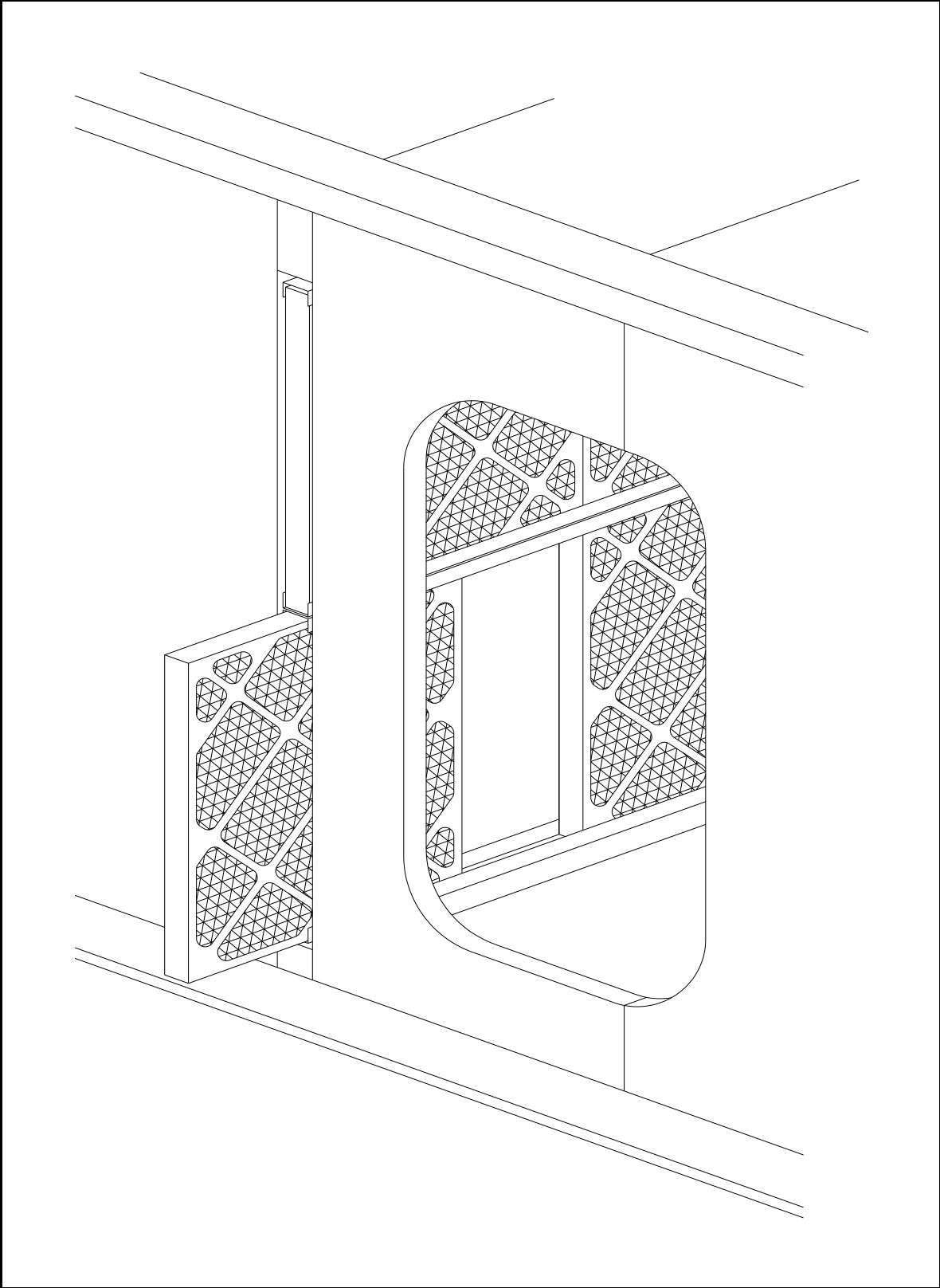

Figure 39: Slide Out Pre-Filter Access.

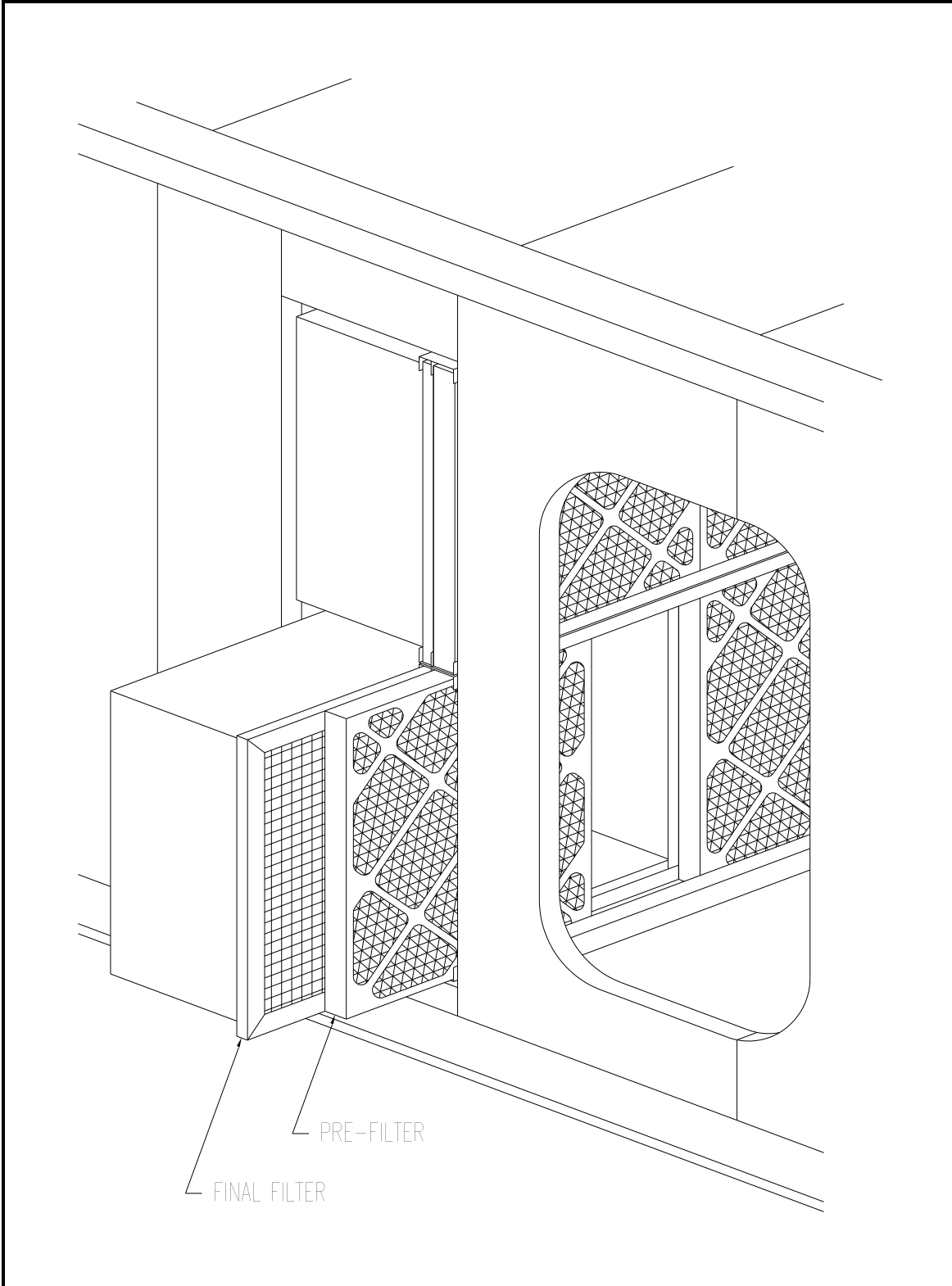

Figure 40: Pre-Filter and Final Filter in a Common Slide-Out Rack.

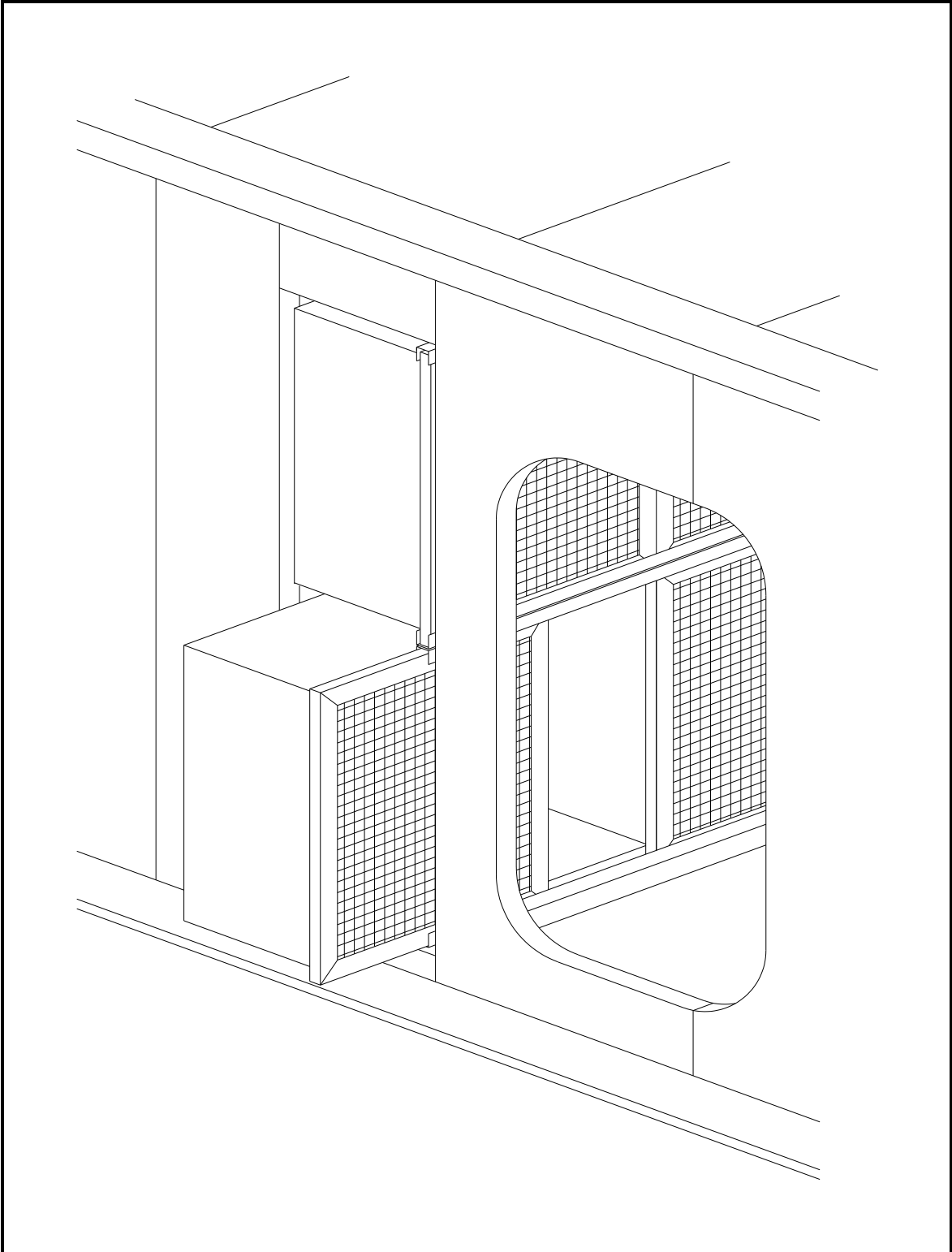

Figure 41: Final Filter Slide-Out Rack.

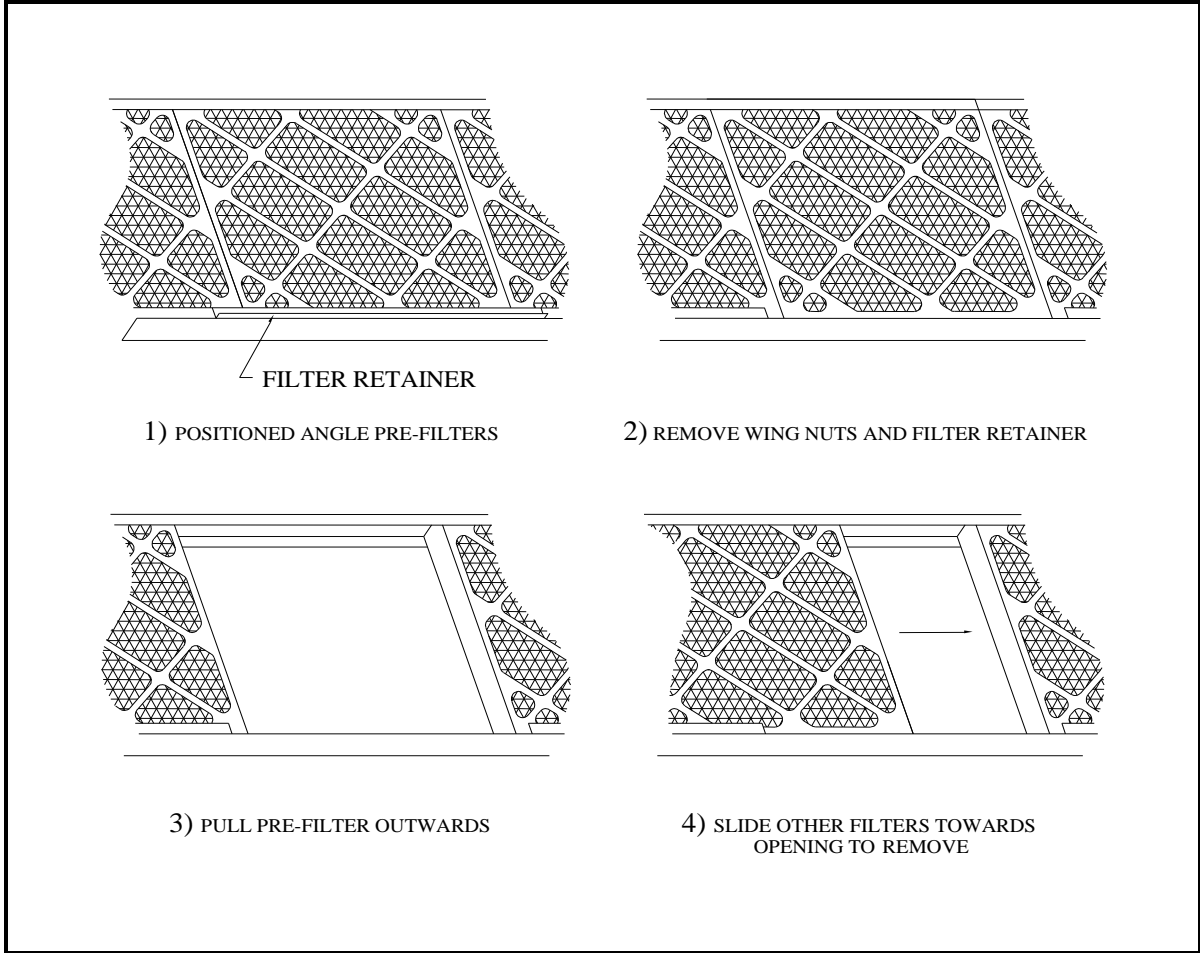

Figure 42: Lift-Out Angle Filter Rack Access Sequence.



Figure 43: Lift-Out HEPA Filter Installation.

Four sheet metal retaining clips are provided for each HEPA frame. The HEPA filter must be placed into the frame first. A clip is then slid into the each of the 4 corners, with the rectangular slots of the clip engaging the formed tabs of the frame. The threaded bolt can then be tightened, compressing the filter gasket to the frame for sealing. The bolt should be hand-tightened only, as the filter and/or clip may be damaged by over-tightening.

## **SECTION 8: START-UP AND MAINTENANCE**

### **START-UP**

Pre-start checklist:

- Damper actuators open the appropriate dampers prior to fan start-up. Failure to open the dampers can result in excessive pressure and cause damage to the duct work or the unit casing. The control sequence should never close all inlet dampers at once while the fan is rotating.
- Inlet vane actuators open to a minimum position prior to start-up or immediately upon start-up. The inlet vanes should open a minimum of 15% to prevent fan surging and excessive vibration. To reduce starting power, the vanes can remain closed during start-up but should be opened at least 15% as soon as the fan reaches full speed.
- The control sequence does not permit free wheeling of a second fan. If the unit is equipped with more than one fan in the same airstream, the control sequence should start both fans simultaneously or provide braking on one fan while it is idle and the other is running. If braking is not provided, the airflow from one fan may rotate the second fan backwards. If the second fan is started while it is running backwards, excessive current draw will result and the electric motor may be damaged.
- Ensure fan rotates freely.
- Ensure fan bearing and drive part set screws are tightened securely.
- Ensure fan wheel is clean and free of debris.
- All objects upstream of the fan intake have been secured.
- Power wiring is correctly connected and the supply voltage has been verified.
- Electrical connections may have come loose in shipment due to vibration. Visually check that all connections are secure before connecting power.
- All required safety guards are in place.
- Fan restraints have been changed from shipping position to operating position.
- All personnel are clear of the fan discharge and inlet area.
- Piping to the unit has been correctly installed and sealed.
- All of the condensate drains have been properly trapped.
- Unit is level.
- All doors on the unit are closed. If the doors are not closed, the air pressure can cause them to close suddenly and with force sufficient to cause bodily injury.
- Ensure heating and / or cooling components are set up to provide the design discharge temperature. Discharge temperatures above or below the design values may result in damage to the unit.

### **Trial "Bump":**

- Apply power to check fan wheel rotation.

- Check the direction of rotation of the fan wheel(s). If the fan is running backwards, switch the power wires on two phases of the 3 phase power supply to reverse the direction of the motor rotation.
- Visually check drive alignment

### **Initial inspection while the unit is first running:**

- Check the unit casing for any leakage points. Potential leakage points are: where the piping enters the unit, field assembled joints at unit splits, duct connections to the unit, where electrical conduit enters the unit.
- Where safety permits, observe the vibration response of each fan during ramp-up and coast down, and program the VFD to skip any resonant frequencies.
- Re-tension the belts and re-tighten all set screws after the first 24 hours of operation.

## **UNIT MAINTENANCE**

### **Coils**

Clean coils regularly as required. Coils can be cleaned with water spray or steam. Check for damage to the coil fins and straighten them as required.

### **Drain Pan**

Clean the condensate drain pans regularly. Remove any foreign objects which may obstruct drainage.

Check the drain trap for any sediment which may be built-up in the bottom of the trap and prevent drainage.

Winterize the drain trap each year before the drain piping or drain pan will be

exposed to freezing air. Change the trap back to operating condition before the cooling season starts.

### **Filters**

Change the filters regularly. Pressure drop readings can be used to determine when a filter should be replaced.

Filter manufacturers recommend their filters be replaced when the measured filter pressure drop is roughly twice the value of the initial pressure drop.

Energy costs are directly related to the internal pressure drop of the air handling unit. Operators may be able to reduce energy costs by replacing filters earlier.

When pre-filters and cartridge or bag filters are in the same bank, the following change-out procedure is recommended:

Start with clean pre-filters and clean final filters. Use the filters until the combined pressure drop is roughly double the combined initial pressure drop of each filter. Change the pre-filters and continue to use the final filters. Repeat this procedure until the combined pressure drop across the new pre-filters and original final filters is double the initial clean value. At this point, remove the pre-filters and run the final filters alone until the pressure drop reaches the desired maximum. At this point change to new pre-filters and new final filters.

### **Dampers**

Inspect the dampers periodically. Check that all linkages are operating smoothly and that the damper blade seals are in good condition. Clean the damper rod bushings.

## Casing

The external casing should be cleaned occasionally to prevent build-up of foreign material which can cause corrosion. The required frequency of cleaning depends on the location of the unit. If any damage to the paint is found, remove any corrosion and repaint the surface.

## Access Doors

Check the condition of the gaskets around the door.

## Cleaning

Clean the inside of the unit regularly with a disinfectant to prevent the building up of dirt and the growth of microorganisms, which can negatively affect the indoor air quality. Clean all metal surfaces including walls, racks, partitions, floors and heat transfer surfaces.

## FAN MAINTENANCE

### Lubrication

The fan should be turned off and locked out to prevent accidental start-up of the fan during lubrication procedures.

Proper lubrication of bearings helps to assure maximum bearing life. Lubricate fan bearings according to the tables shown below. These lubrication intervals are for normal operating conditions. For applications with high temperatures, continuous operation, or a dusty or corrosive environment, the lubrication frequency should be increased. Use one-half of listed interval for vertical shaft applications or for 24 hour operation.

Observation of the condition of the grease expelled from the bearings at the time of re-lubrication is the best guide as to whether

re-greasing intervals and the amount of grease added should be altered.

Greases are made with different bases. There are synthetic base greases, lithium base, sodium base, etc. Avoid mixing greases with different bases. They could be incompatible and result in rapid deterioration or breaking-down of the grease.

When re-lubricating, use sufficient amount of grease to purge the seals. Rotate the fan wheel during re-lubrication where good safety practice permits. **Do not over lubricate.**

Where extended lube lines have been provided, visually check the condition of the bearing during lubrication where possible.

Always lubricate bearings prior to extended shutdown or storage and rotate shaft monthly to aid corrosion protection.

### SUGGESTED LUBRICANTS:

Shell Alvania #2  
Texaco Premium RB2  
Mobilith SHC100  
or equivalent

**BALL BEARING PILLOW BLOCKS  
RE-LUBRICATION SCHEDULE IN MONTHS**

SHAFT DIAMETER	FAN SPEED (rpm)						
	500	1000	1500	2000	2500	3000	3500
0.5" - 1.69"	6	6	5	3	3	2	2
1.94" - 2.44"	6	5	4	2	2	1	1
2.56" - 2.94"	5	4	3	2	1	1	1
3.44" - 3.94"	4	3	2	1	1	1	

**SPHERICAL ROLLER BEARING SOLID PILLOW BLOCKS  
RE-LUBRICATION SCHEDULE IN MONTHS**

SHAFT DIAMETER	FAN SPEED (rpm)						
	500	1000	1500	2000	2500	3000	3500
1.19" - 1.44"	6	4	4	2	1	1	1
1.69" - 2.19"	4	2	1.5	1	0.5	0.5	0.5
2.44" - 3.44"	3	1.5	1	0.5	0.5		
3.94" - 4.94"	2.5	1	0.5				

**SPHERICAL ROLLER BEARING SPLIT PILLOW BLOCKS  
RE LUBRICATION SCHEDULE IN MONTHS**

SHAFT DIAMETER	GREASE QTY	FAN SPEED (rpm)					
		500	750	1000	1500	2000	2500
1.44" - 1.94"	0.50 OZ	6	4.5	4	4	3.5	2.5
2.19" - 2.69"	0.75 OZ	5	4.5	4	2.5	2.5	1.5
2.94" - 3.94"	2 OZ	4.5	4	3.5	2.5	1.5	
4.44" - 4.94"	4 OZ	4	4	2.5	1		
5.44" - 5.94"	7 OZ	4	2.5	1.5			

## Wheel and Shaft Maintenance

Inspect the wheel and shaft for dirt build-up, corrosion, and signs of fatigue. Clean the components and apply new coatings as required. Check the balance of the assembly.

## Drive Maintenance

Where safety permits, visually inspect the drive as it is running. Squealing of belts indicates that the drive is improperly tensioned or that there is foreign material on the belt or sheave. On a properly tensioned drive, there will be a slight bowing on the slack side of the belt.

With the fan shut off and locked out, visually inspect the belts for wear. Unacceptable operation will result if belts are excessively worn or cracked. Inspect the sheaves. If the sheaves are worn down, the belts may not be able to transmit full power.

## Tensioning V-Belt Drives

Correct tensioning of the V-belt drive is an important factor for successful operation of the fan. The belts must be tight enough to overcome slippage

at the peak load. Most often the peak load on a fan belt is during start-up. Care must be taken however, not to over-tension the belts. Over-tensioning can cause excessive loading on the fan bearings and shorten belt life. The best tension for a V-belt is the lowest tension at which the belt will not slip under full load. The belts can be tightened or loosened by adjusting the position of the fan motor.

## MOTOR MAINTENANCE

### Inspection

Inspect motor at regular intervals. Keep motor clean and vent openings clear.

### Lubrication

No lubrication is required before start-up. The motor bearings have been lubricated in the factory.

Recommended greases:

Exxon Mobil Polyrex EM  
Chevron USA SRI No. 2

The motor bearings should be re-lubricated according to the following schedule:

HOURS OF SERVICE PER YEAR	DUTY	HP RANGE	LUBRICATION FREQUENCY (months)
5000	NORMAL	1/8 - 7.5	16
		10 - 40	10
		50 - 150	5
CONTINUOUS	NORMAL	1/8 - 40	5
		50 - 150	2.5
SEASONAL	NORMAL	1/8 - 150	BEGINNING OF SEASON
CONTINUOUS	SEVERE	1/8 - 40	1
		50 - 150	0.5

## **SECTION 9: AIRFLOW DISPLAY AND TROUBLESHOOTING**

### **HAAKON CAREL AIRFLOW DISPLAY GUIDE**

#### **Normal operation:**

When 24 vac power is applied between the 1 and 2 terminals in the AFMS enclosure, it will initially display a loading screen, then move automatically to the main screen which reads the words Haakon Industries at the top. The Main Screen displays total airflow for the associated fans with the appropriate labels.

The 10x10x6 enclosure that houses the Carel and the terminal strip has factory wiring to the fan section where the Differential Pressure transducers are mounted. When a differential pressure is applied to either set of the ¼ inch pressure inlets at the side of the DP transducer, the corresponding 0-10Vdc signal will be sent to the Carel controller. The Carel screen will display a calculated CFM value (metric option available in L/s. Units also switchable by the user). Values below approximately 20% of the design fan volume will display as 0 CFM. The differential pressure input range to the display will vary depending on the model of fan. Each display is programmed for a specific model of fan and is not interchangeable without factory reprogramming. . The formula for the displayed CFM of a specific differential pressure input is displayed on the LCD screen of the Carel controller, viewable by navigating to the menu. The formula applies only to the model of fan to be connected to that input.

Each fan volume displayed has a matching 0-10 vdc signal output (BACnet MS/TP or IP connectivity available) which can be read at the wiring connections. In the Carel settings menu and shown on the Circuit Schematic is the range in CFM that each 0-10 vdc output corresponds to. The scale is linear from 0 to 10 vdc.



Figure 44: Airflow display panel.

### **TROUBLE SHOOTING**

No display:

- Consult the unit wiring diagram and ensure that all required field power supply connections have been made. Check right at the G and GO terminals on the Carel controller. If there is 24vac on these wires and no display on the device it will have to be replaced.

The 0-10 vdc output does not track the displayed value:

- The common of the signal must be connected to the 1 terminal. Any power supply of any connected system must share this common. This common is not normally grounded by Haakon Industries but may be grounded if required by the building control system.

Display will not change from 0 CFM:

- The fan must be moving at least 20% of its design volume before the display will give a CFM reading Dirty filters or duct blockage can cause the air flow to drop below the low limit regardless of fan speed.
- Check that all the connecting tubing from the fan to the display is in good condition. Leaking tubing connections or damaged tubing can result in a loss of signal.
- Check the pressure signal reaching the display.
  - Check the reading on the LCD screen of the DP transducer and see if that matches the reading on the Carel status screen.
  - Use a meter at the DP transducer Signal and Com terminals to check for 0-10Vdc signal.
- Check the polarity of the signal. The low pressure line (blue) should come from the throat of the fan and the high pressure line (red) from the inlet side of the fan.
- Check that the pressure taps on the throat and face of the fan are not clogged with grease or dirt. The holes are very small and if sealed a pressure could be trapped in the line that does not immediately bleed off resulting in a display of CFM without air movement.

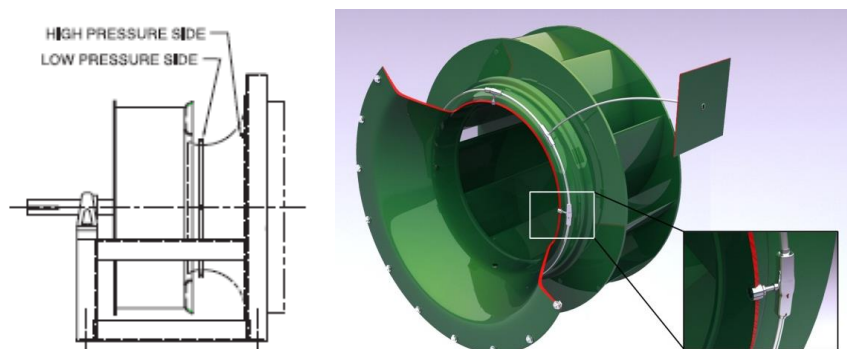

Figure 45: Pressure connection at piezometer ring.

The displayed value does not agree with the calculated value:

- The values may be at opposite ends of their respective accuracy ranges over emphasizing the difference.
- There may be unexpected turbulence in the area of the high pressure pick up point. Certain duct configurations can result in air flow patterns that affect the pressure at the high pressure sensing point. If this is suspected install a static pressure probe in place of the tap hole. Moving the location of the probe may be required to produce an accurate reading.

## **AHU TROUBLESHOOTING:**

The following section is provided as a guide to diagnose problems associated with air handling unit operation.

### **Air capacity is insufficient:**

- 1) There is excessive pressure loss in the duct work.
- 2) The filters are clogged or dirty.
- 3) Inlet vanes or dampers are improperly set or not open.
- 4) Fan is not rotating in the correct direction.
- 5) There is leakage in the supply duct.
- 6) Loose or slipping belts.
- 7) Dirty fan blades.
- 8) Inaccurate measurement. In field systems, an appropriate plane must be chosen for a pitot tube traverse where the airflow is reasonably uniform. VAV boxes, or other airflow measuring devices not provided with the AHU, may not provide an accurate measurement of the unit airflow rate.

### **Condensate drain pan overflowing:**

- 1) Drain trapping is incorrect.
- 2) Drain trap is not primed.
- 3) Condensate line or trap is plugged.
- 4) Unit is not level and condensate is not draining.

### **Excessive noise or vibration:**

- 1) Fan restraints have not been changed from shipping position to operating position.
- 2) Air flow is restricted and the fan is surging. Check that the inlet vanes and dampers are opened sufficiently.

- 3) Failed fan bearing.
- 4) Adjustable frequency drive is causing motor noise.
- 5) Misaligned drives are causing belt noise.
- 6) Over-tensioned belts.
- 7) Damage to rotating parts
  - fan wheel
  - sheaves
  - fan shaft
- 8) Set screws on fan wheel or drive sheaves have loosened.
- 9) Foreign material on the fan wheel.
- 10) Fan is running backwards.

### **Moisture on walls downstream of cooling coil:**

- 1) Air leakage where coil or drain piping enters unit.
- 2) Damaged door seal causing air leakage.
- 3) Leakage through field assembled split.

### **Motor fails to start:**

- 1) Incorrect field wiring.
- 2) Overload tripped.
- 3) Blown fuse or tripped circuit breaker.
- 4) High inrush currents associated with high efficiency motors are causing nuisance tripping of a circuit breaker, overload, or fuse.
- 5) Tripped cut-out device such as freezestat or door interlock switch if so equipped.

**Motor overheating  
(High Amperage):**

- 1) Belts too tight.
- 2) Excessive current draw caused by incorrect fan rotation.
- 3) Low supply voltage.
- 4) Open phase.
- 5) Damaged motor.
- 6) Sheave misalignment.
- 7) Pressure loss is less than design on a forward curved fan system.

**Belt squealing:**

- 1) Incorrectly tensioned belt.
- 2) Worn belts or sheaves.
- 3) Foreign material on belts or sheaves.

**Short belt life:**

- 1) Tensile members of belt damaged during installation.
- 2) Worn sheave grooves.
- 3) Oil or grease on belts or sheaves.
- 4) Belt dressing used on the belts.

**Bearing overheating or failure:**

- 1) Bearings not lubricated.
- 2) Bearings over-lubricated.
- 3) Belts are over-tensioned.

**Failure of starter control  
transformer:**

- 1) The remote fan start contacts are a large distance from the air handling unit and the resistance load in the

wiring is overloading the control transformer.

- 2) Field-installed control wiring is overloading control transformer.

**Contactors Failure:**

- 1) Fan is short-cycling.
- 2) Field-installed wiring may be overloading control transformer.

**Damper does not open:**

- 1) Actuator is not functioning.
- 2) Damper linkage is adjusted incorrectly.
- 3) Damper bearing surfaces are contaminated and require cleaning and lubrication.

## APPENDIX A: DAMPER ACTUATOR MOUNTING

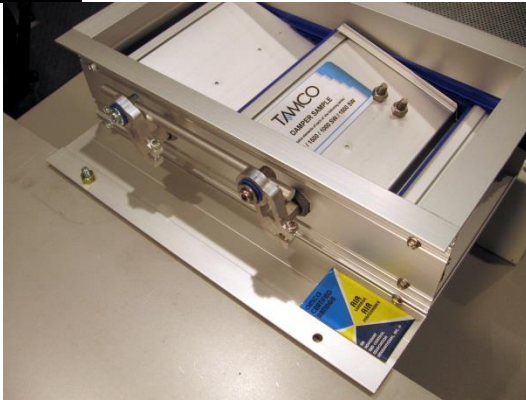

1. TAMCO damper showing the linkage side. → The actuator goes on the opposite side.

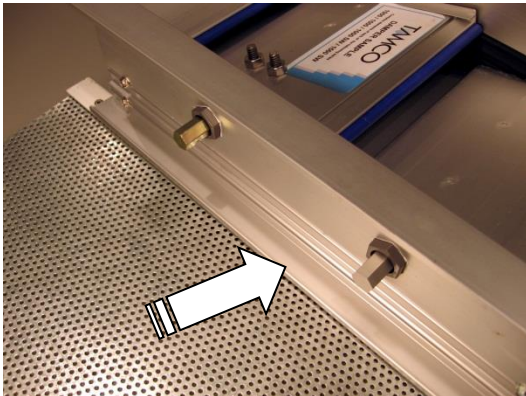

2. TAMCO damper showing the non-linkage shaft side. → The extendable shaft for the actuator is the non-aluminum one.



3. Loosen the shaft U-bolt nuts in order to extend the shaft for the actuator. ( 7/16" wrench ).



4. Slide the shaft out about 3 1/2" past the damper frame.



5. Tighten the shaft U-bolt nuts to secure the extendable shaft in position. ( 7/16" wrench ).

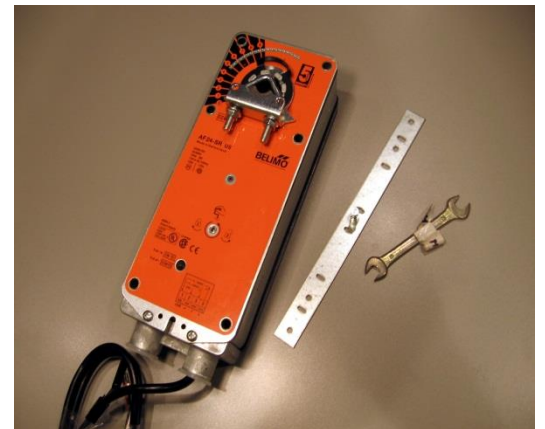

6. BELIMO damper actuator with Anti-Rotation strap & 10mm wrench.

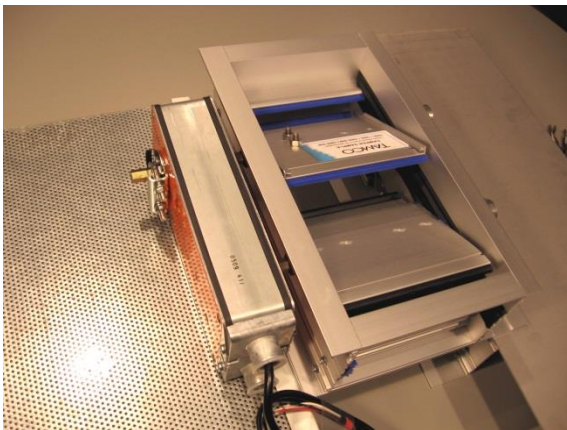
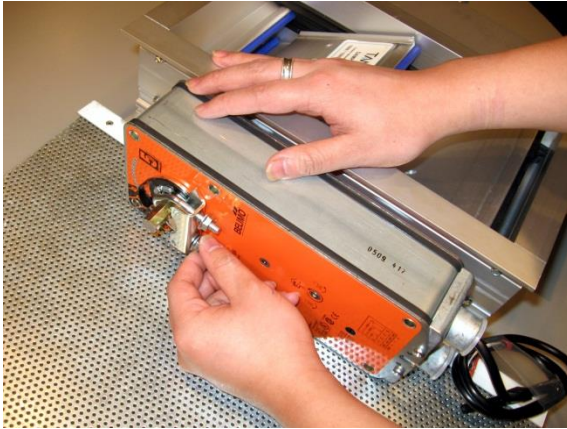

7. Slide the actuator over the extended damper shaft into the mounting position, alternatively for some types of actuators such as a pneumatic type, a crank-arm assembly would be mounted on the extended shaft and the crank-arm would be linked to the actuator.  
 → Follow the actuator manufacturer's instructions for actuator set-up.

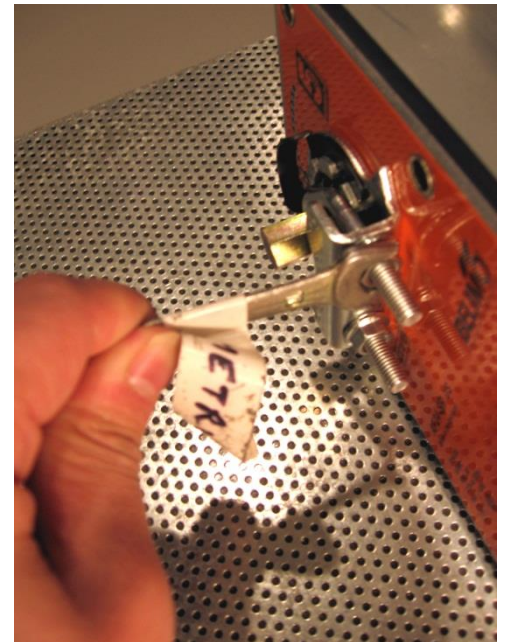

8. Tighten the BELIMO Actuator V-bolt with a 10mm wrench.  
 → Other types of damper shaft mount Actuators will be similar.

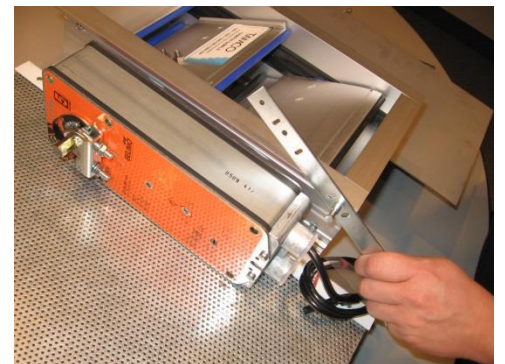

9. The BELIMO Anti-Rotation strap will have to custom bent to fit the situation before it can be attached to secure the damper.  
 → Other types of damper shaft mount Actuators will be similar.

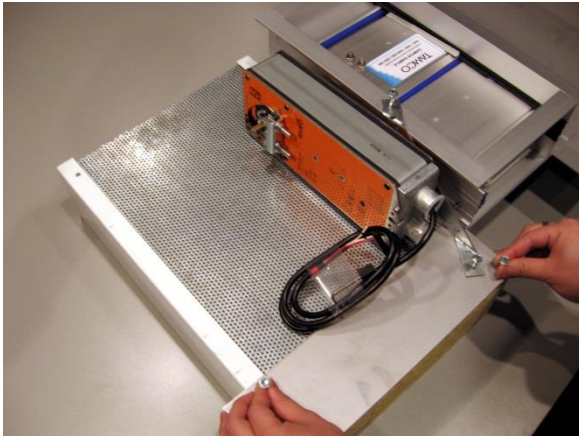

10. In many cases a sheet metal mounting strip will have to be made up and attached to the unit wall panel in order to be able to securely mount the Anti-Rotation strap.



11. Close-up of the BELIMO Anti-Rotation strap mounting.

## **APPENDIX B: TABLE OF FIGURES**

Figure 1: Assembly of Haakon Roof Curb.....	3
Figure 2: Unit mounted on Roof Curb.....	3
Figure 3: Lifting of a unit with 8 lifting points.....	4
Figure 4: Lifting of a unit with roof mounted lifting brackets. ....	4
Figure 5: Split Unit. ....	5
Figure 6: Caulking of Split Unit Joining Surface.....	5
Figure 7: Base Joining Flanges Detail.....	6
Figure 8: Base Joining Flat Strip Detail.....	6
Figure 9: Base joining T-Strip Detail. ....	6
Figure 10: Joining Strip Detail. ....	7
Figure 11: Joining Strip Cross Section. ....	7
Figure 12: Roof Joining Detail.....	7
Figure 13: Roof Split End Cap Detail. ....	8
Figure 14: Roof Split Peak Cap Detail. ....	8
Figure 15: Vestibule/Corridor Joining Angle Detail. ....	9
Figure 16: Cross section of Roof Curb.....	10
Figure 17: Roof curb flashing cross-section. ....	10
Figure 18: Curb Restraint Bracket. ....	11
Figure 19: Hanging Unit.....	12
Figure 20: Front view of hood.....	13
Figure 21: Rear view of hood. ....	13
Figure 22: Connection of Hood(s) to Unit.....	13
Figure 23: Isolator and Earthquake Restraint. ....	14
Figure 24: Changing Restraints to Operating Position.....	15
Figure 25: Connection of Duct. ....	16
Figure 26: Detail of Duct Connection. ....	16
Figure 27: Trapping Dimensions. ....	19
Figure 28: Evaporative Humidifier.....	23
Figure 29: Media Cross Section.....	24
Figure 30: Electrical Fittings.....	26
Figure 31: Electrical Penetration Detail.....	27
Figure 32: Filter Holding Frames. ....	29
Figure 33: PH Style Final Filter Upstream Installation in Holding Frame. ....	30
Figure 34: Pre-Filter & Peripheral Headered(PH) Final Filter in Common Holding Frame..	31
Figure 35: Pre-Filter and Peripheral Headered (PH) Final Filter in Common Holding Frame with spacer for separate pre and final filter gauge installation. ....	32
Figure 36: Upstream Pre-Filters and Final Filters in a Frame Downstream of Filters.....	33
Figure 37: Downstream Lift-Out Final Filter Installation in Holding Frame.....	34
Figure 38: Lift-Out Pre-Filter Rack Filter Access Sequence. ....	35
Figure 39: Slide Out Pre-Filter Access. ....	36
Figure 40: Pre-Filter and Final Filter in a Common Slide-Out Rack. ....	37
Figure 41: Final Filter Slide-Out Rack.....	38
Figure 42: Lift-Out Angle Filter Rack Access Sequence. ....	39
Figure 43: Lift-Out HEPA Filter Installation.....	40
Figure 44: Airflow display panel. ....	46
Figure 45: Pressure connection at piezometer ring. ....	47



**Haakon Industries (Canada) Ltd.  
11851 Dyke Road  
Richmond, B.C. Canada  
V7A 4X8**